

# Helmut Mauell GmbH Partner of Energy Suppliers

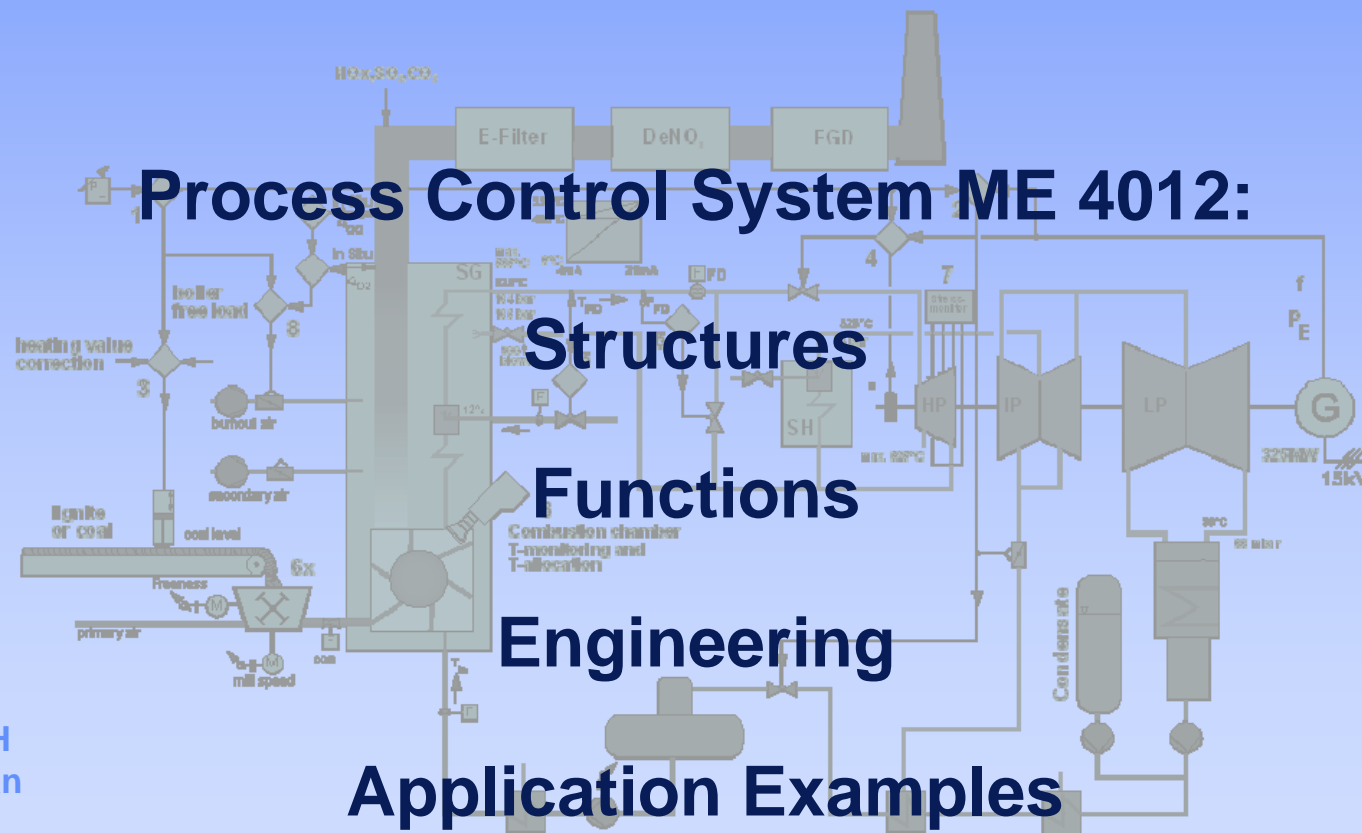

## Process Control System ME 4012

<b>1. Helmut Mauell GmbH</b>	<b>Slide</b>	<b>4. Engineering</b>	<b>Slide</b>
· Vertical Integration & Project Organisation	2	· ME-DRP 5 Functional Scope	14
· References and Technological Competence	3	· ME-DRP Hardware- Structure Documentation, Configuration, Diagnosis	15
<b>2. Power Station Control ME 4012</b>	<b>4</b>	· ME-DRP 5 Project management and structures	16
· Automation Unit AE 4012	5	· Control loops analysis and modelling	17
· Process Control and SCADA, Signal Run- and Cycle- Times	6	· Measurement recording	17
· ME-VIEW System Architecture	7	· Controller parameter optimisation	18
· ME-VIEW Control Room, Power Plant House Load Dispatcher	8	<b>5. Application Examples</b>	
<b>3. Functions / Function redundancy</b>		· Power Plant Boxberg Unit R 670 MW	19
· Modern Control Algorithms, applied in Power Station Control	9	· Schematic Boxberg, Unit R 670 MW	20
· Turbinespeed measuring unit (control 1oo2, protection 2oo3, SIL3)	10	· Turbine Control System Tihange 3 1.050 MW and 2x TFP	21
· Steam- Turbine protection, security and availability	11	· SWM Süd combined heat and power station 750 MWel. 1.700 MWth.	22
· Overspeed protection (SIL 3)	12	· ME-VIEW Control Room SWM Munich South, GuD combined heat and power	23
· Turbine Hydraulic System	13	· Turbine Control System Eskom Matimba, 6x 675 MW (RSA)	24

# Power Station Control

# Vertical Integration & Project Organisation



- Development
- Consulting
- Engineering
- Manufacture
- Installation
- Commissioning
- Training
- Product Maintenance
- Worldwide Service



- **Unit Control**
- **Failsafe Burner Control**
- **Steam Turbine Control and Protection (incl. Turbine Hydraulic System)**
- **Gas Turbine Control and Protection**
- **Station Houseload and Dispatcher Control**
  
- **Power Station Auxillary Plants**
- **Waste Incineration Plants**
  
- **Pump Storage Power Plants**
- **River Power Plants**
  
- **Nuclear Power Plants:**
  - **Turbine Control and Turbine Protection**
  - **Turbine Hydraulic and Servo Motors**
  - **Signalling and Message System**
  - **Criteria Computer**
  - **Control Room Technology**
  - **Station Control Rooms**

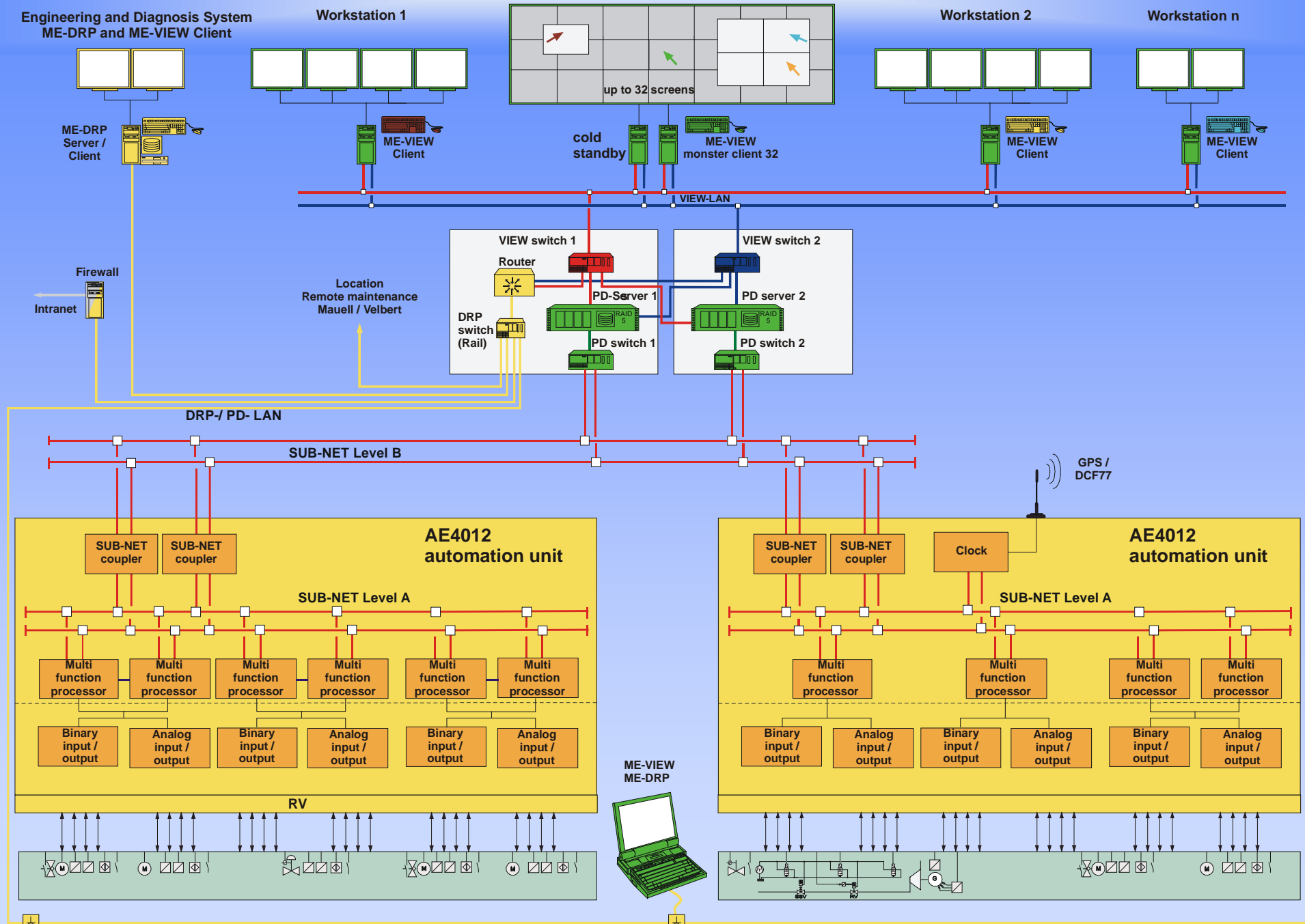

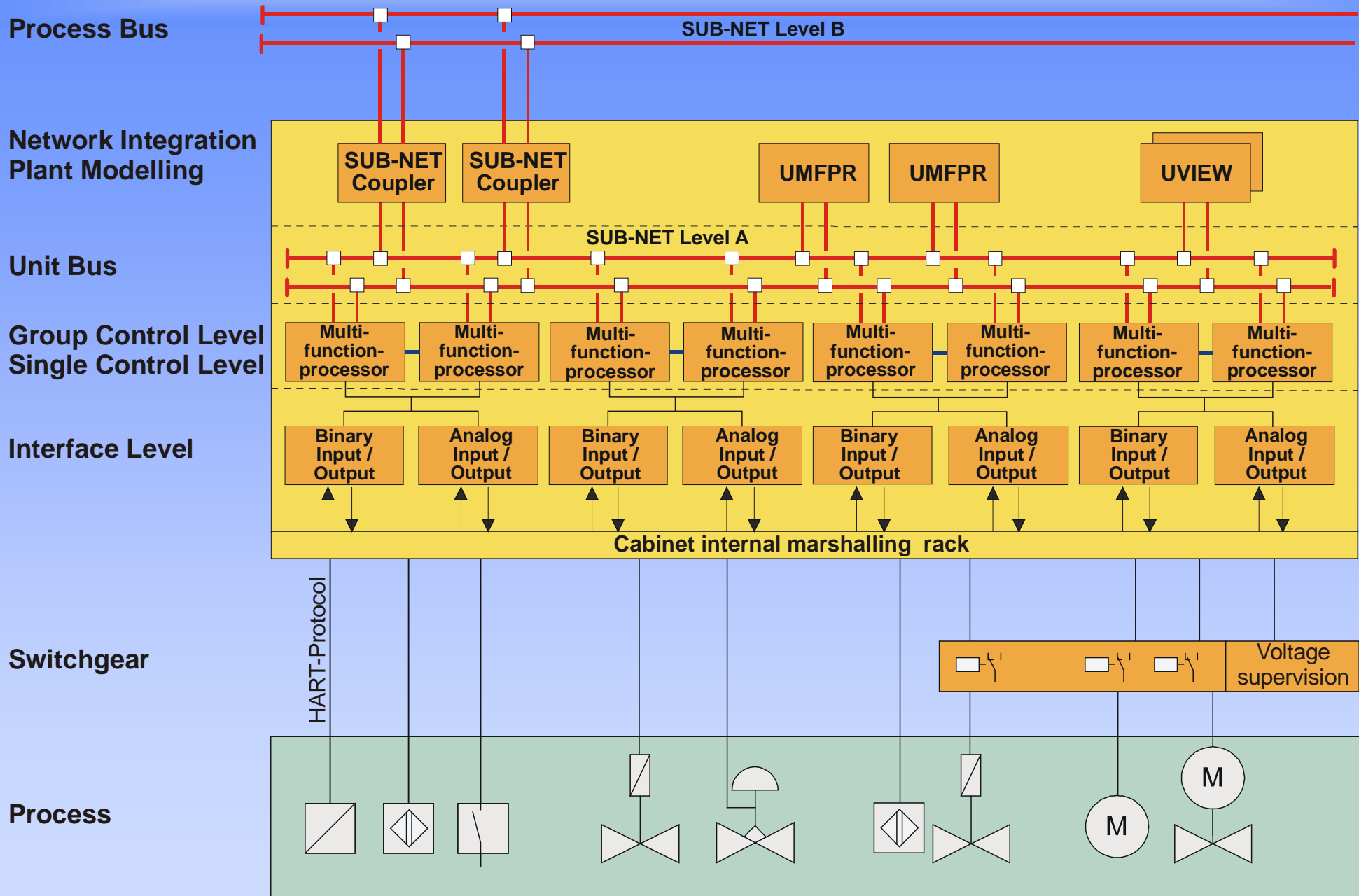

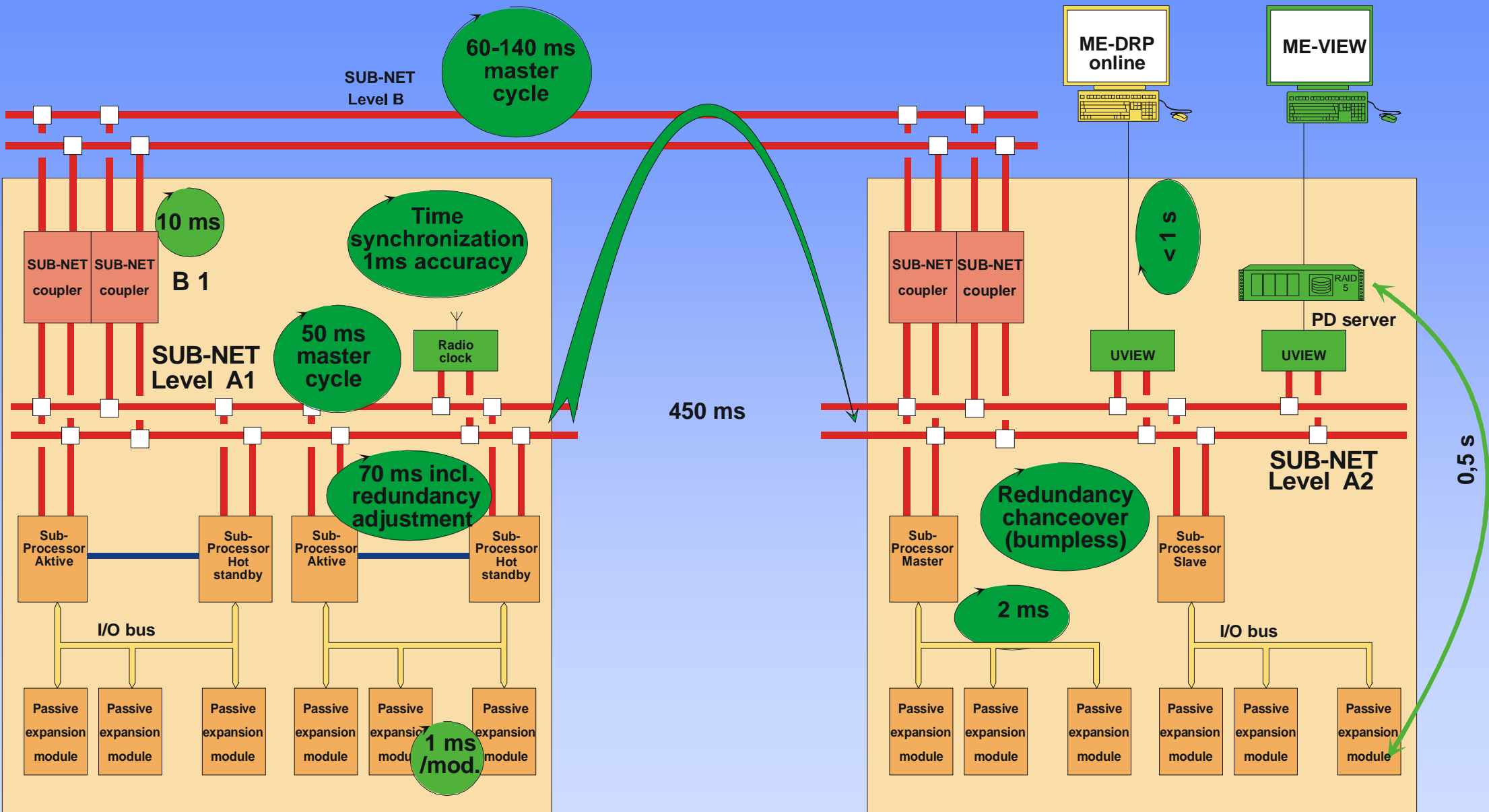

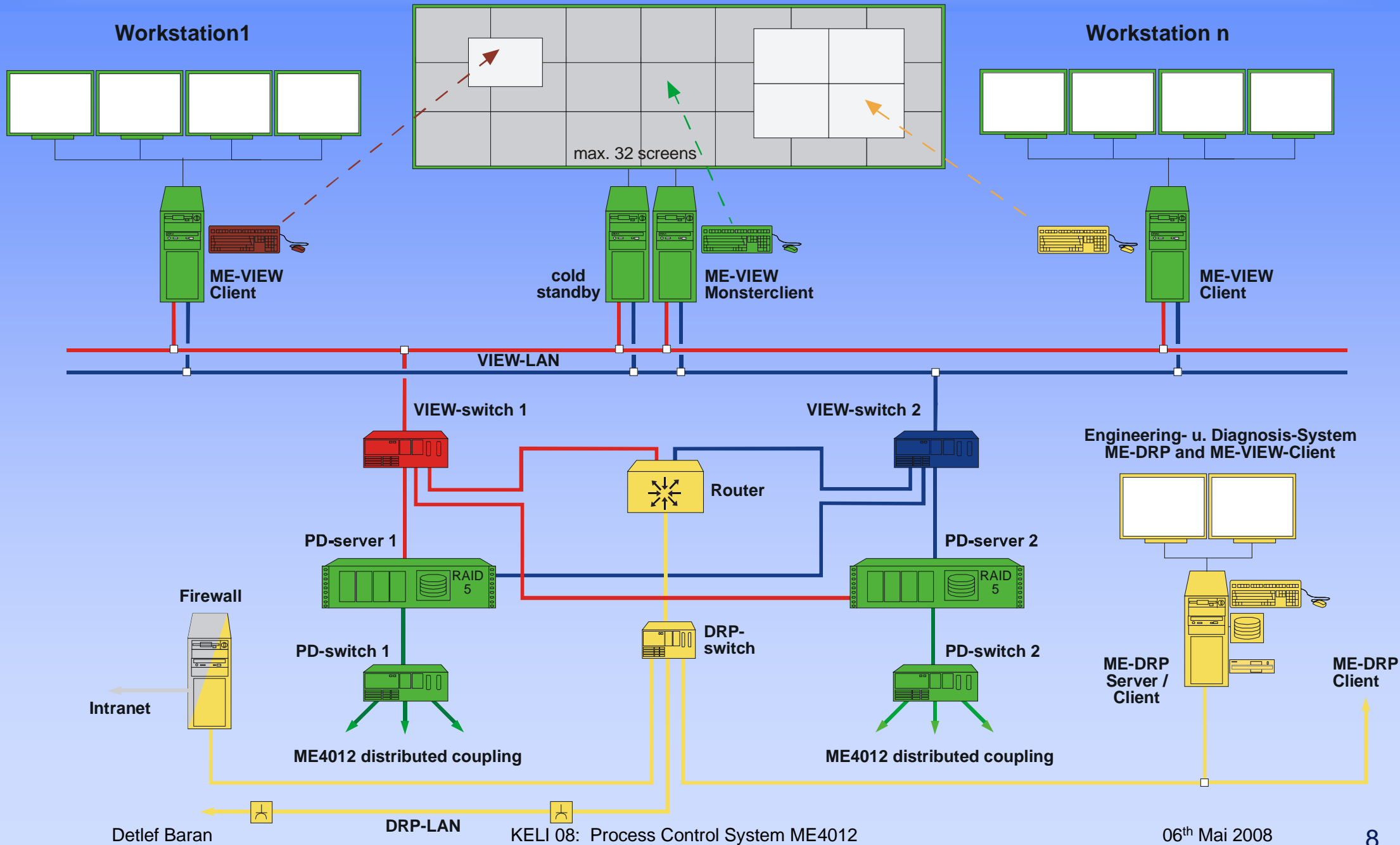



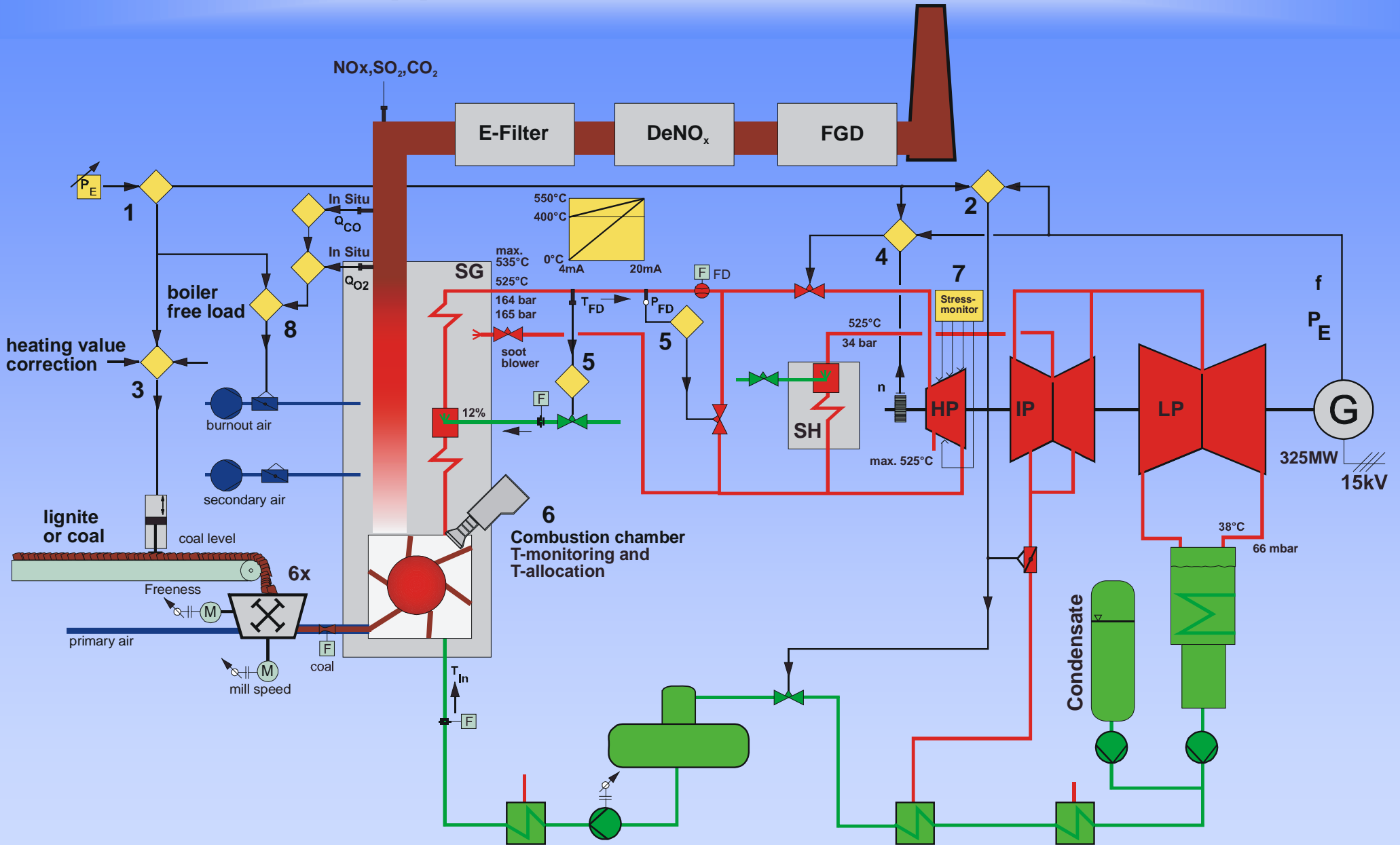

1. Unit model (smooth load control)  
2. Condensate stop control

3. Multi-variable Fuzzy control  
4. Turbine Speed- / Load Control

5. Calculation-guided control  
6. Combustion analyse control

7. Turbine Stress Monitor  
8. Boiler free load calculation

# Processinterface digital speed measurement :

Accuracy : 0,004 % = +/- 2mHz at 50 Hz netw. frequency

Signal resolution : 0,5 mHz

Signal scan cycle : 4 ms

Measuring range : >3 - 3600 U min<sup>-1</sup>

Long-term- and temperature- stability due to digital acquisition and processing

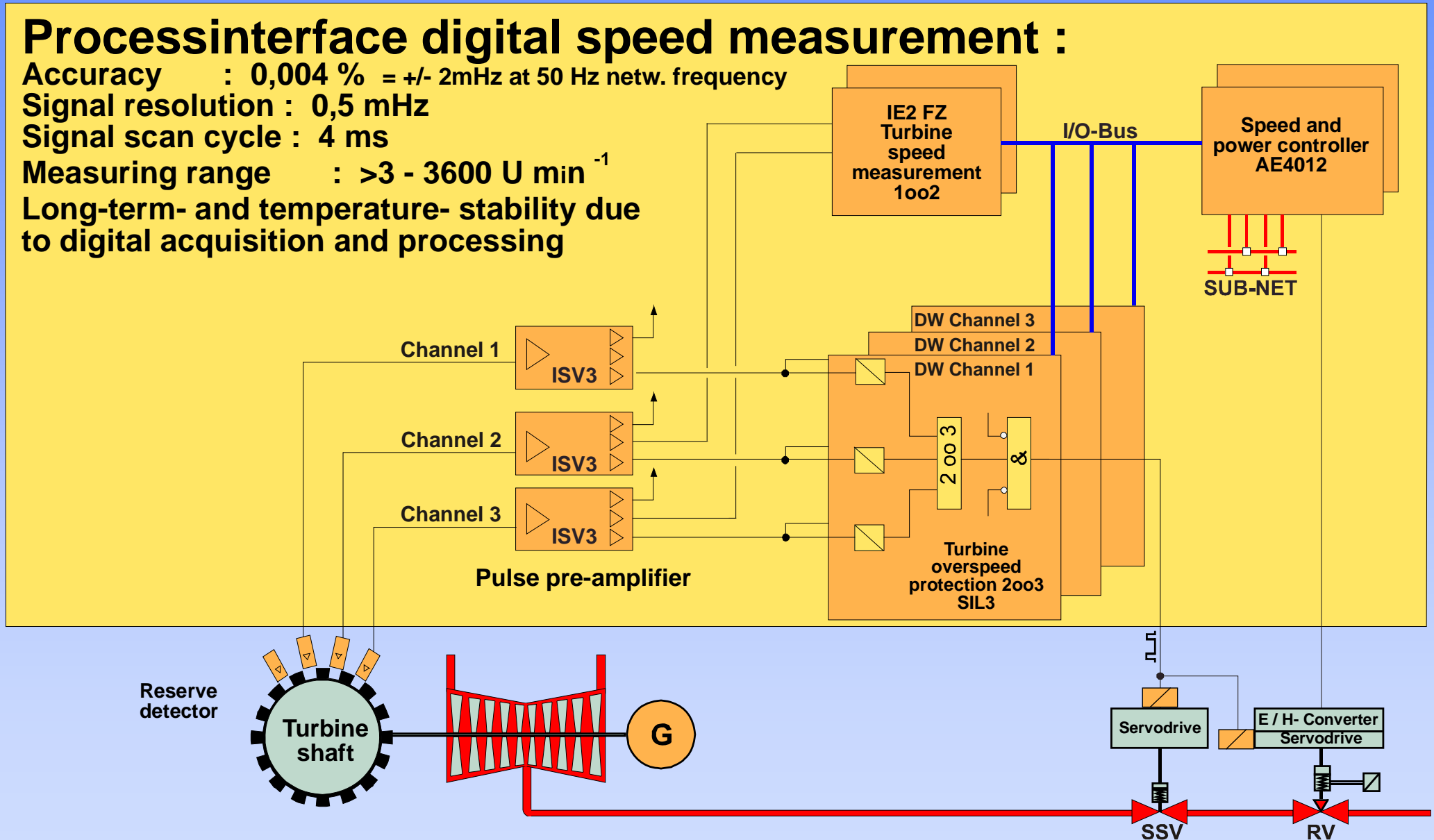

# Steam-Turbine Protection security and availability

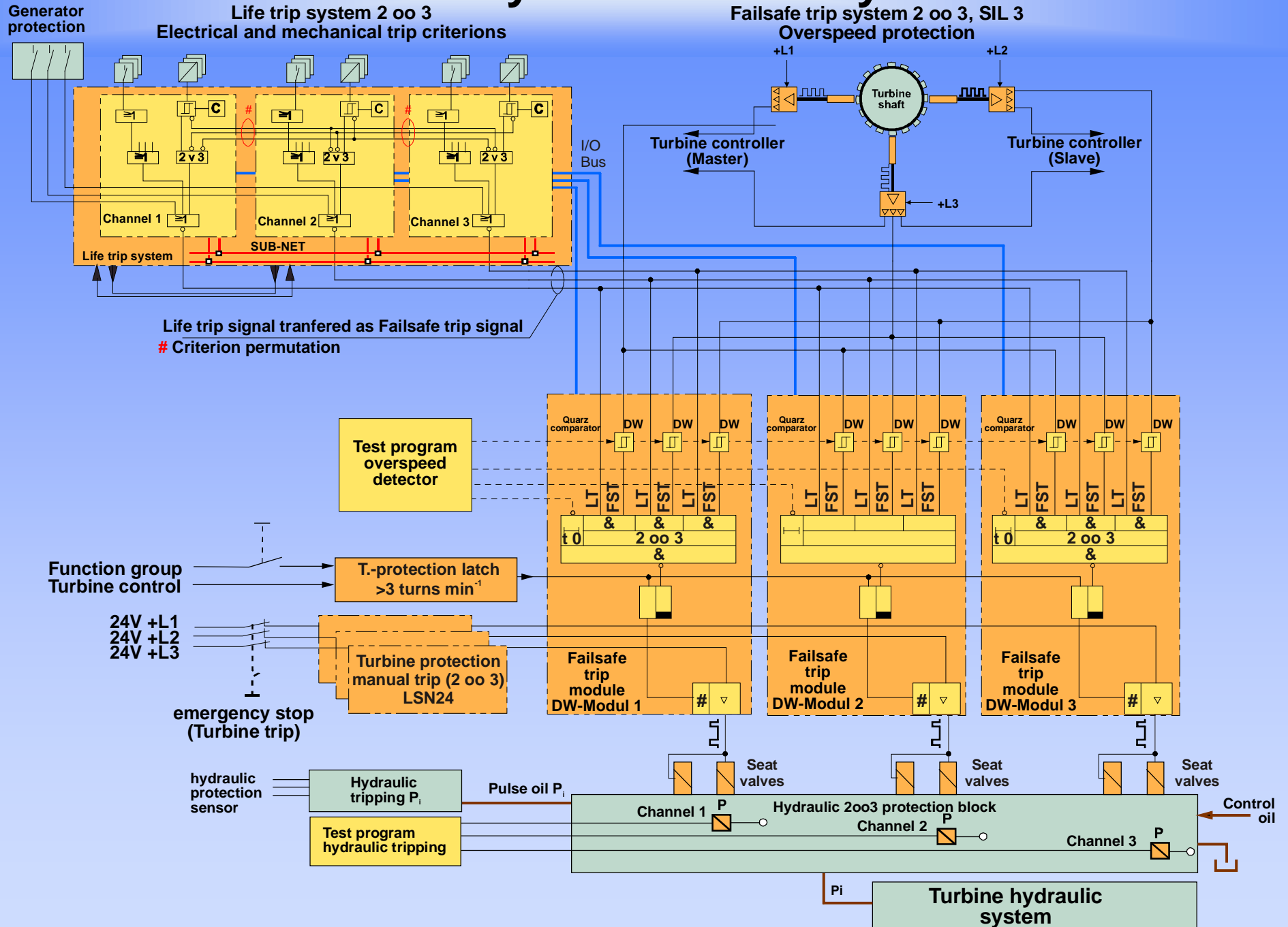

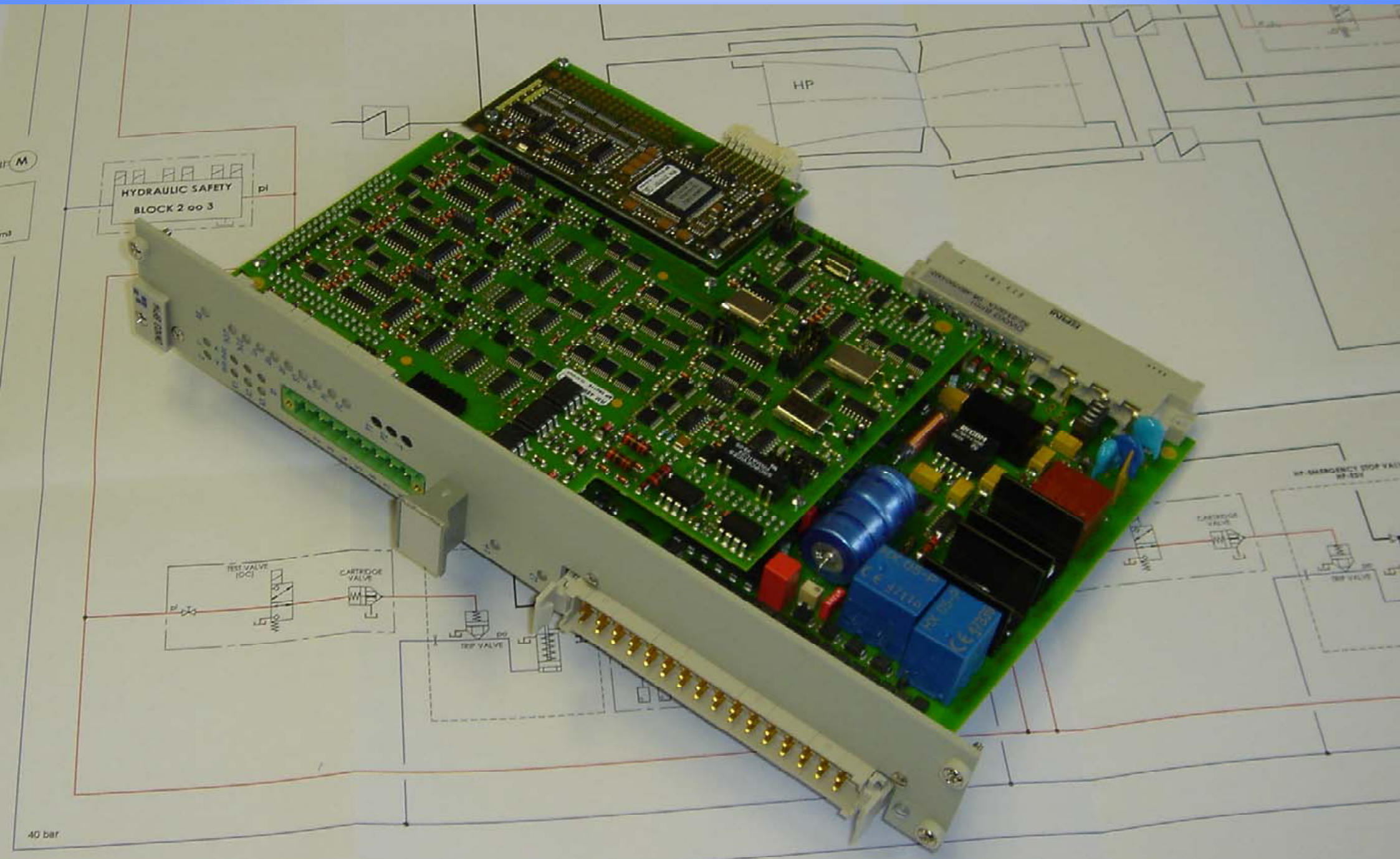

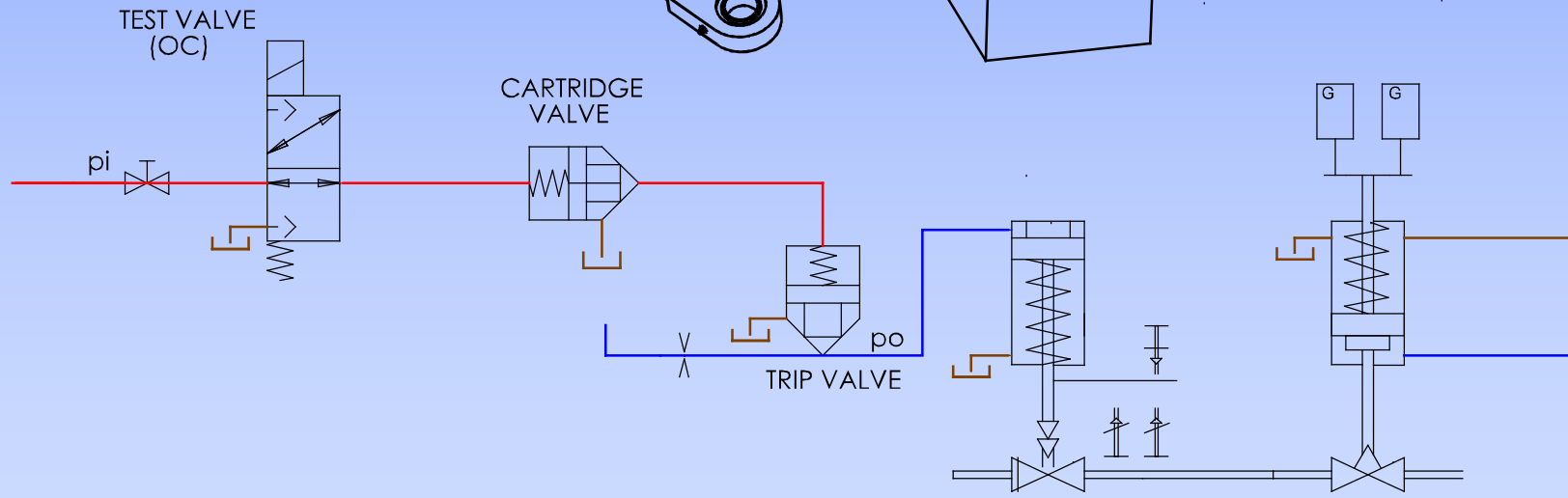
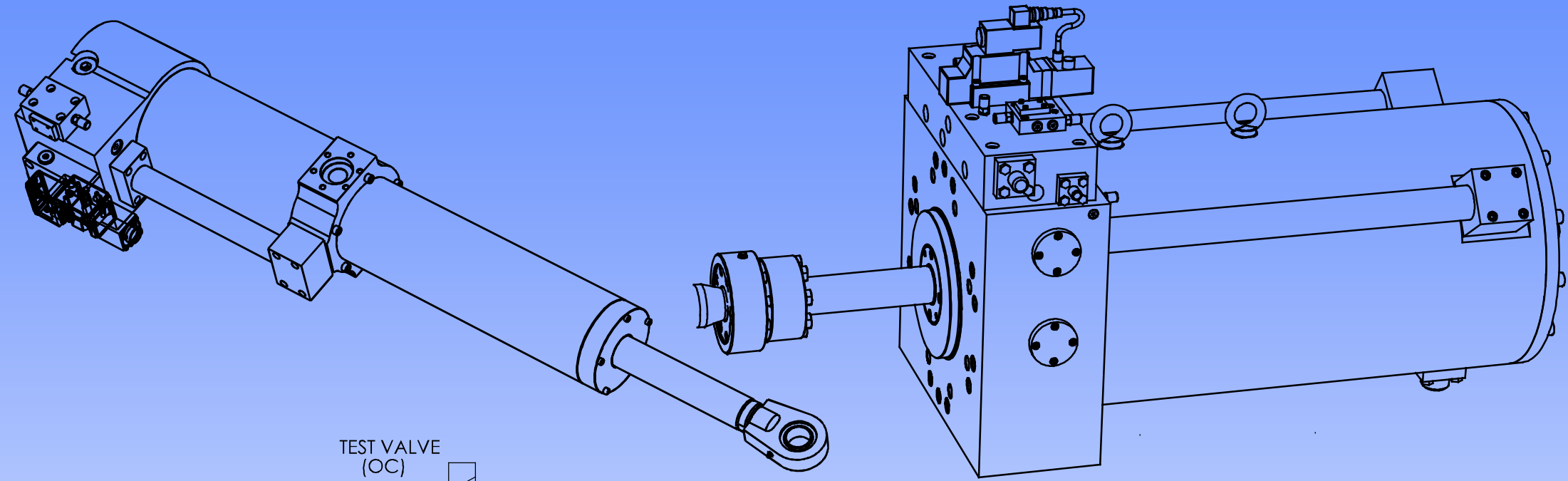

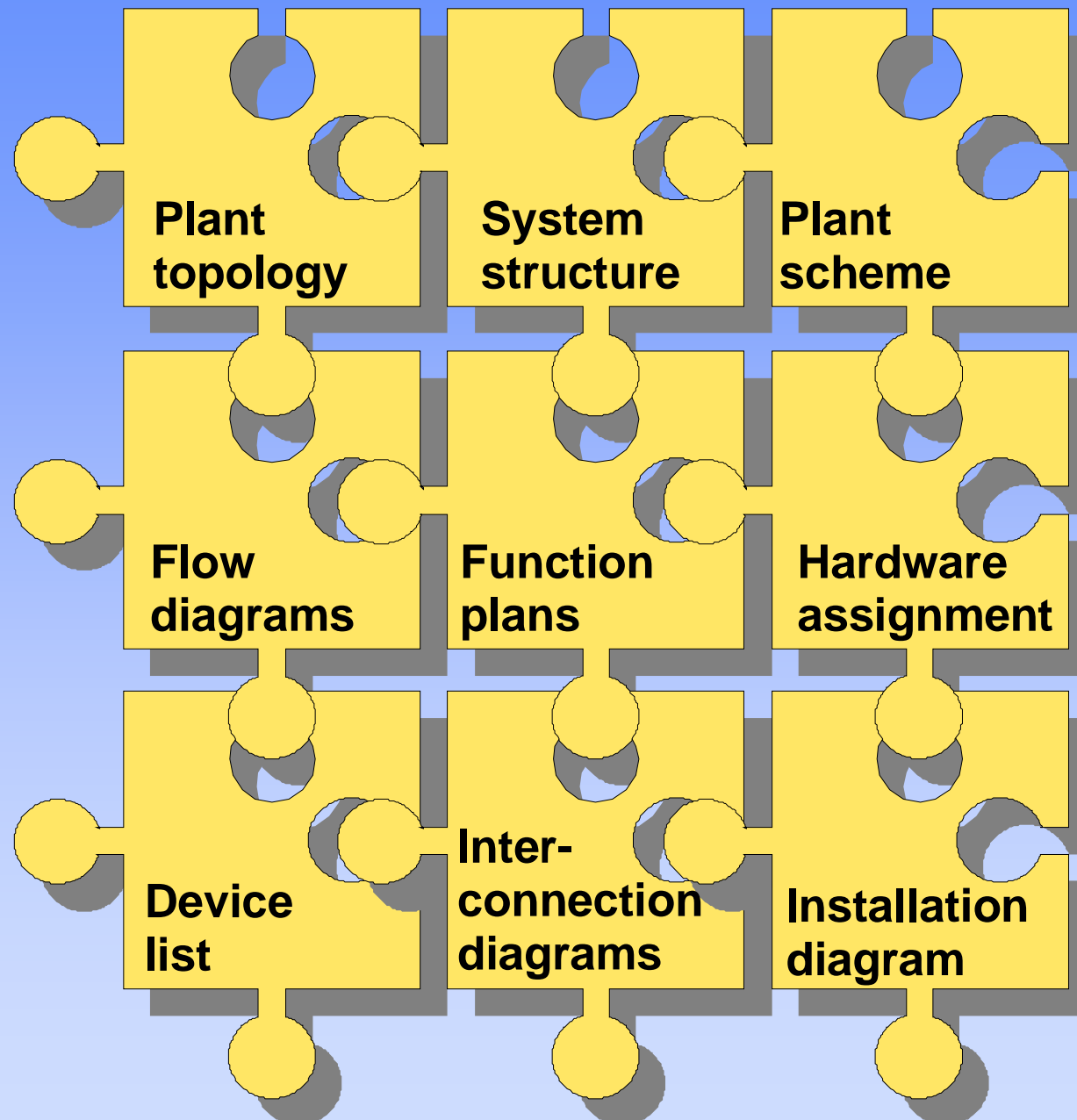

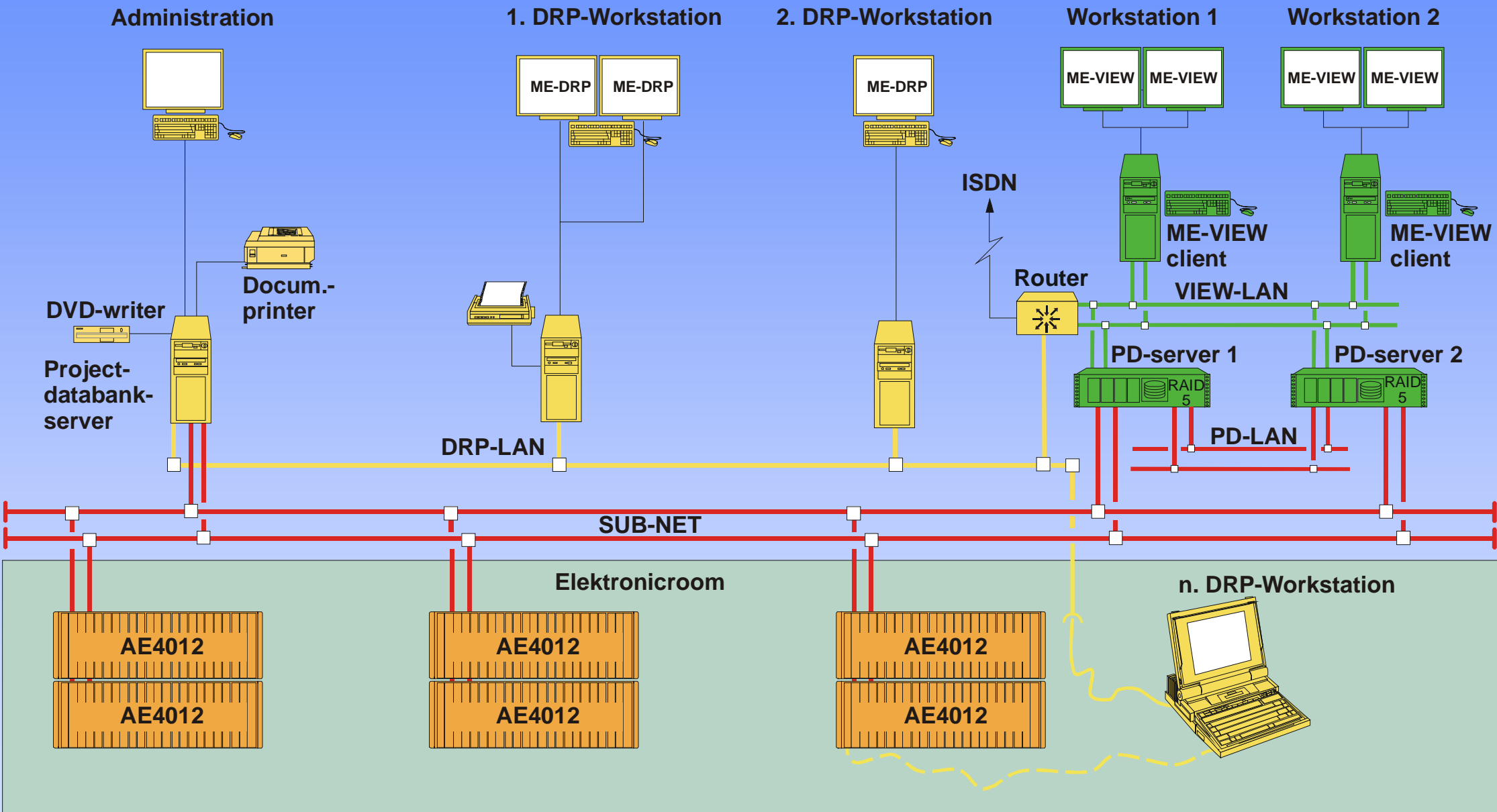

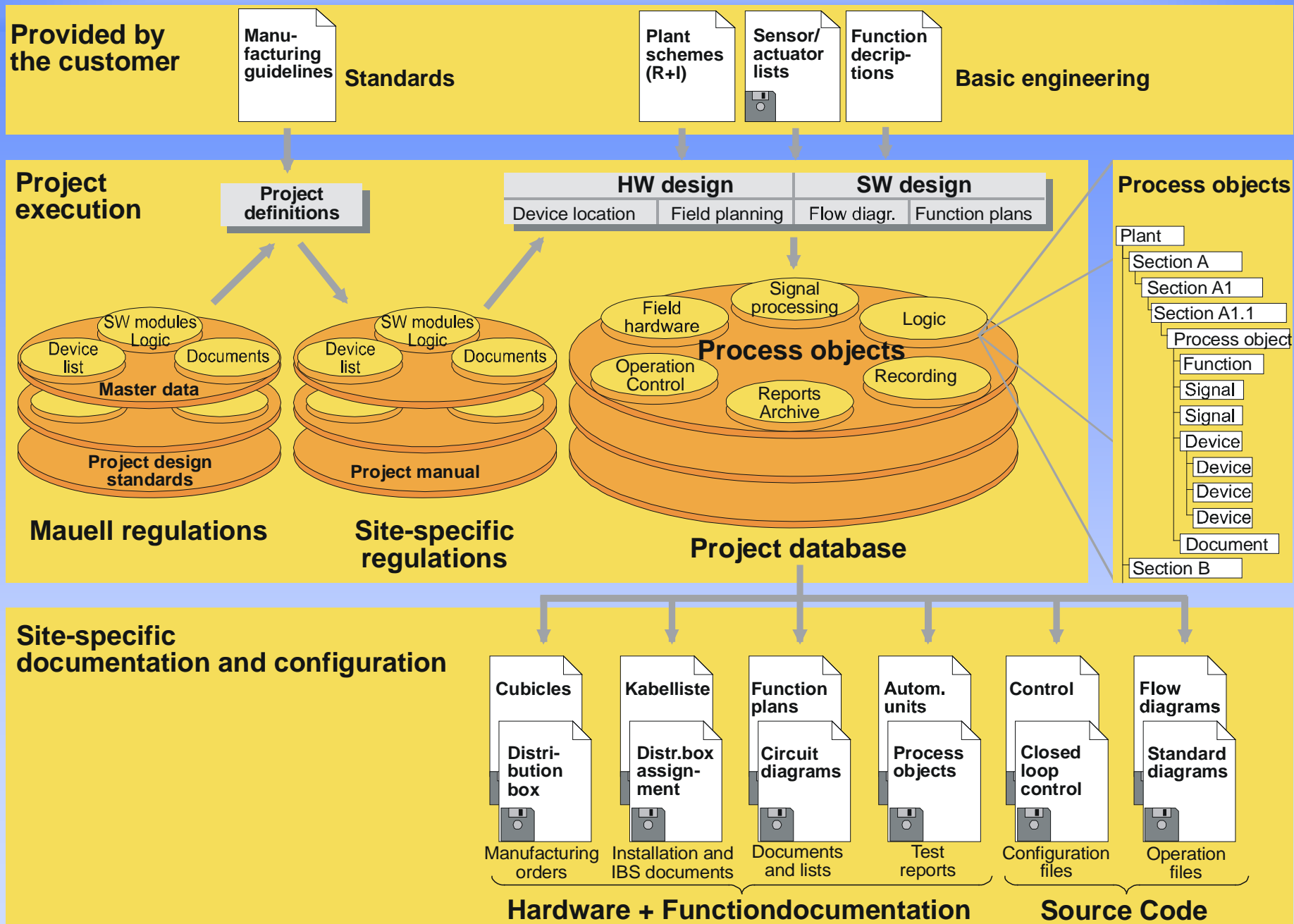

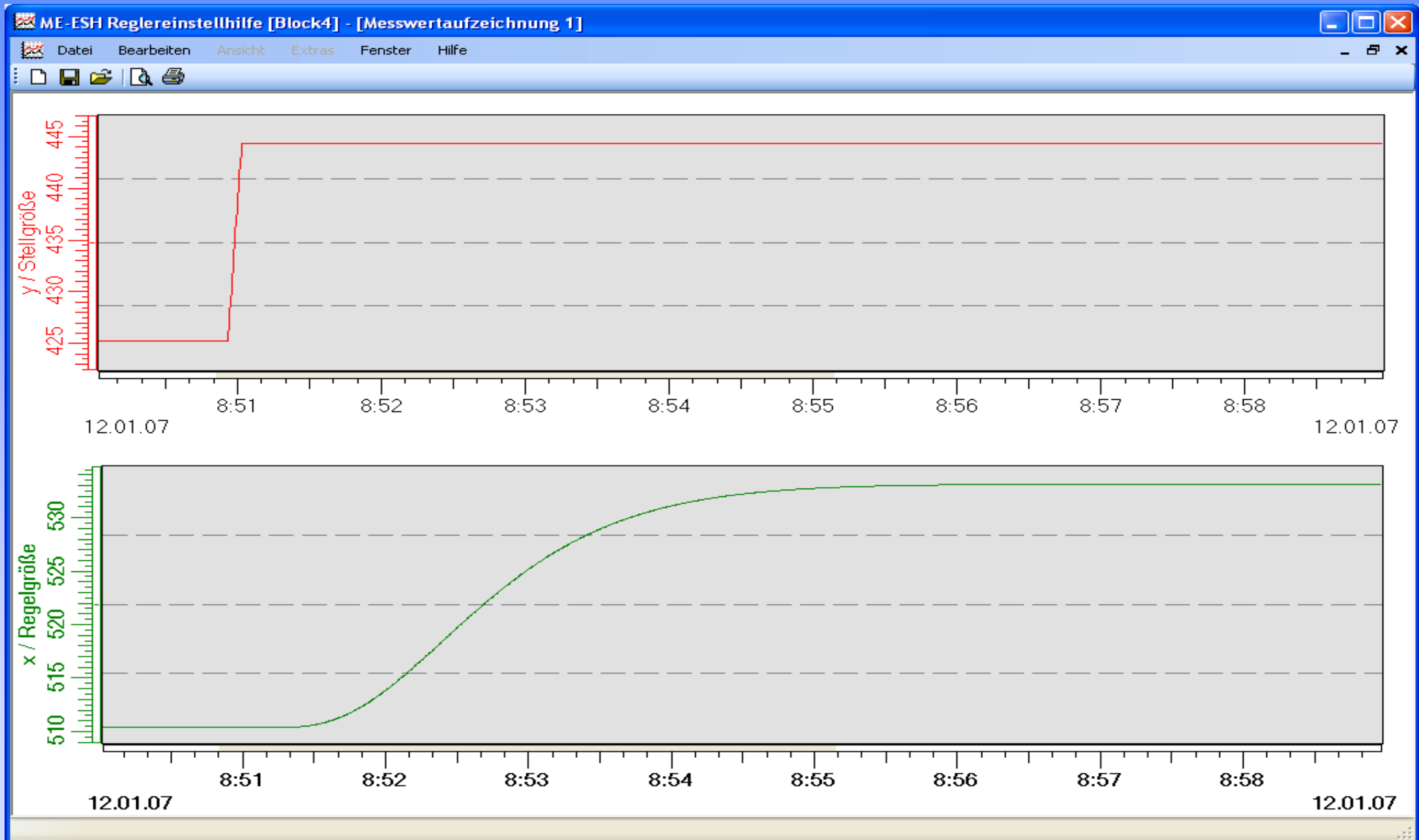

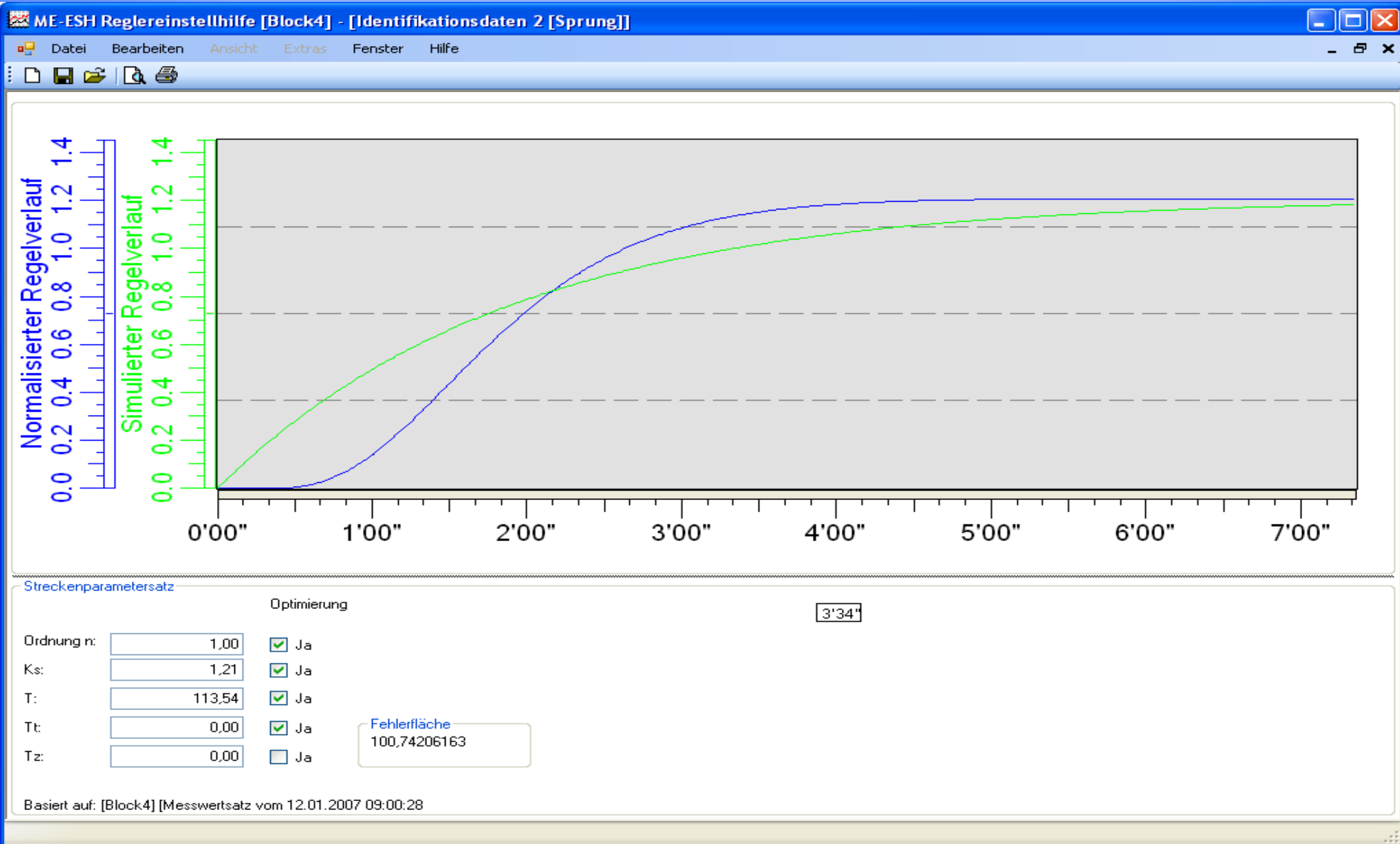



- Base load operation
- Availability > 91 %
- Unit guide control 50 % to 103 %
- High level of automation
- Fulfillment Transmission Code
- Net efficiency > **43,7 %** (main steam:  $T = 600 \text{ }^\circ\text{C}$ ;  $p = 285 \text{ bar}$ )
- Coal demand: 4,5 Mio. t/a
- Specific CO<sub>2</sub>-Emission: 924 g/kWh

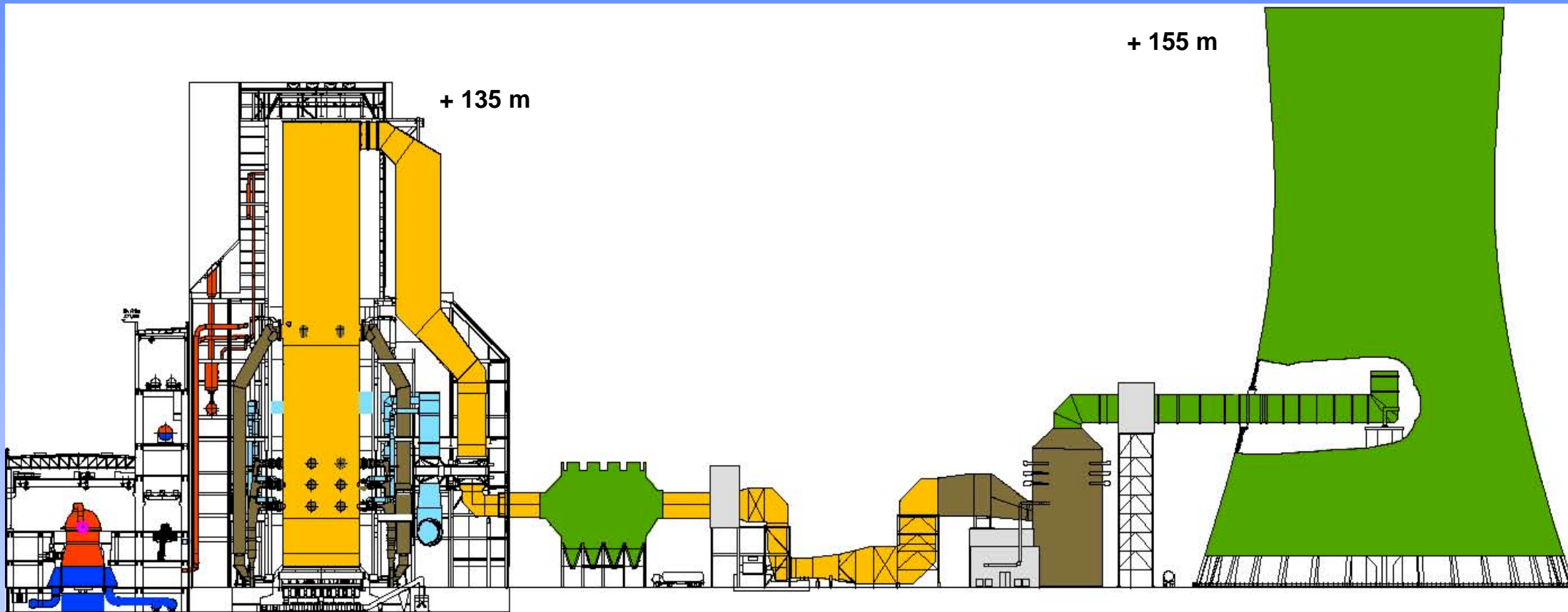

Turbine building

Steam generator

Electrical filters

Induced draft fan

Flue gas desulfurization plant

Cooling tower and flue-derivation



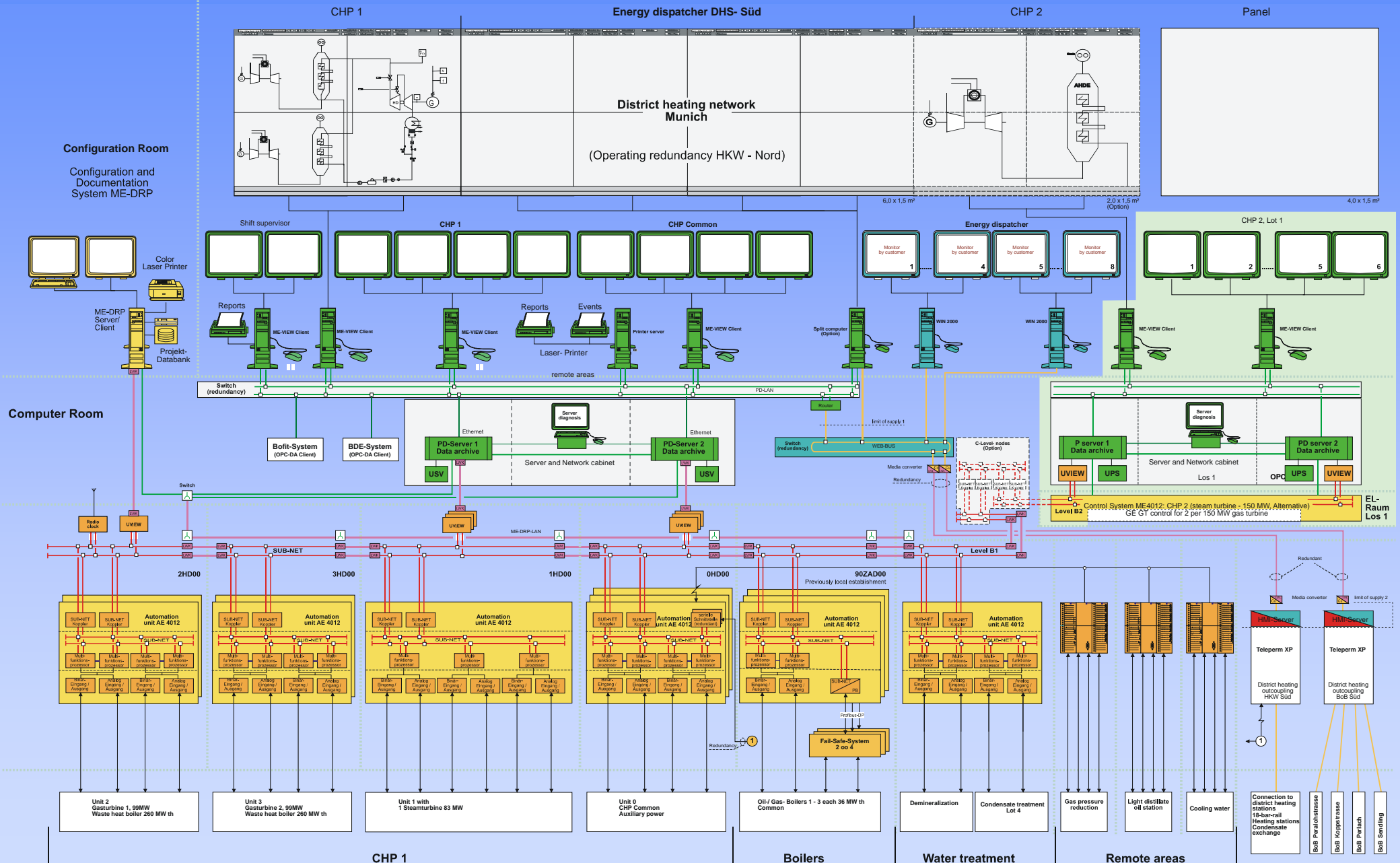

# ME 4012 ME-VIEW Control Room, Munich South combined heat and power station







## Partner for the energy supply industry

If you want to efficiently convert your energy into power . . .



  
*... your partner  
in automation*



### Power station control systems

Coal-fired and nuclear power plants, steam and gas turbines, gas and steam plants, incineration plants and hydroelectric power stations



### Power distribution control systems

Telecontrol systems, station control systems for power grids



### Control room technology

Power distribution and power plant control rooms, dispatch control rooms for gas, oil, water and district heat, traffic control centres and simulator control rooms

Helmut Mauell GmbH  
Am Rosenhügel 1-7 · D-42553 Velbert, Germany  
Tel. +49 (0) 20 53 1 30 · Fax +49 (0) 20 53 1 34 03 · [www.mauell.com](http://www.mauell.com)

601\_4012\_0008