

Couplers



KRB .., KRC ..,
KRD .., KRE ..,
KRS .., KVF ..



Please note:

Texts introduced by this headline provide some special information about some technical requirements which you should pay special attention to.

The contents of this brochure may be subject to modification for the purpose of technical improvement. The regulations applicable to installation and commissioning must be observed. The information is supplied without liability.

Contents	Page
Couplers: Task and Overview	4
Coupler KRB 11	6
Coupler KRB 12	8
Couplers KRC 12 and KRC 12A	10
Couplers KRD 22 and KRD 22S	12
Coupler KRD 22U	14
Couplers KRE 12, KRE 24 and KRE 24A	16
Couplers KRS 12 and KRS 12K	18
Coupler KVF 11	20
Dimension Drawings	22

Please note:

To meet the 'Safe isolating' conditions according to VDE 0106 Part 101, EN 61010-1, all terminal screws must be tightened (including the screws of unoccupied terminals).

The Task

Amplification of analog and binary commands is required in quasi all process engineering plants as this is a precondition for transmitting the technical concepts of programmable controllers and feedback control loops down to the machine level.

Depending on the task involved we differentiate between:

- Solenoid valves and motors
- Electrical actuator drives and variable speed drives
- Frequency converters for speed-controlled motors
- Pneumatic or hydraulic control and servo valves.

Special couplers and power output stages matched to the different applications are used to provide a system-compatible interface between the automation unit and the power or switchgear section.

The couplers available are primarily used for controlling solenoid valves and switchgear for motors and actuator drives. They provide electrical isolation between the control and load circuits and amplify the signals coming from the electronic programmable controllers. The load circuits of those devices that are intended for direct switching of solenoid valves are protected separately. Some coupler models are capable of detecting power failures and of providing an electrically isolated error signal to the monitoring logics. Depending on the coupler model, it is possible for the load circuit to

be monitored for interrupts (wire break) and short circuits, resulting in the output of an error signal.

Important command and error signals are indicated by LEDs. On some coupler models, the commands to the actuator devices can be simulated by means of a test probe.

The components of the couplers are mounted in robust plastic enclosures. These enclosures comply with protection class IP 40 (terminals IP 20) and are suitable for installation on standard rails (DIN / EN 50 022, 35 mm width).

Cabling costs can be reduced significantly if the units are installed close to the consumer (switchgear systems, sub-distributor).

Other designs are in preparation in addition to the couplers shown in this brochure.



Couplers

Type	Input	Output	Supply voltage	Features
KRB 11 KRB 12	1 x 230 V ac 1 x 60 V ac 1 x 48 V ac 1 x 24 V ac 1 x 125 V dc 1 x 110 V dc 1 x 60 V dc 1 x 48 V dc 1 x 24 V dc	KRB 11: 1 floating changeover contact KRB 12: 2 floating NO contacts	230 V ac 60 V ac 48 V ac 24 V ac 125 V dc 110 V dc 60 V dc 48 V dc 24 V dc	<ul style="list-style-type: none"> • Input voltage = supply voltage
KRC 12 KRC 12A	1 x 24 to 60 V dc	2 NO contacts for double-pole switching of the output voltage 1 floating changeover contact for error signal output	24 V dc 60 V dc 48 V dc	<ul style="list-style-type: none"> • Output voltage = supply voltage • Electrical isolation of output and input • Single pole fuse (KRC 12A: 2-pole fuse) • Undervoltage monitoring of output • Output shutdown and error signal output on failure • Variable circuit of error signal output • Command simulation with test probe
KRD 22 KRD 22S	2 x 24 V dc 2 x 60 V dc	2 changeover contacts with common root	24 V dc 60 V dc	<ul style="list-style-type: none"> • Input voltage = supply voltage • KRD 22S: Simulation of input signals with test probe at 24 V dc signalling voltage
KRD 22U	2 x 24 V dc	2 changeover contacts with common root 1 non-floating change- over contact for the output of a 24 V dc error signal	24 V dc	<ul style="list-style-type: none"> • Input voltage = supply voltage • Simulation of input signals with test probe at 24 dc signalling voltage • Undervoltage monitoring of a 230 V ac external supply • Error signal
KRE 12	1 x 24 V dc 1 x 60 V dc	2 NO contacts 250 V dc, 4 A	24 V dc 60 V dc	<ul style="list-style-type: none"> • Relay with blowout magnet for high direct-current loads
KRE 24	2 x 24 V dc 2 x 60 V dc	2 x 2 NO contacts 250 V dc, 4 A	24 V dc 60 V dc	<ul style="list-style-type: none"> • Double command output • 2 relays with blowout magnet for high direct-current loads
KRE 24A	2 x 24 V dc 2 x 60 V dc	2 x 2 NO contacts	24 V dc 60 V dc	<ul style="list-style-type: none"> • Double command output • 2 relays with blowout magnet for high d.c. loads • One parallel relay to each relay NC contacts of the supplementary relays connected in series
KRS 12 KRS 12K	13 to 72 V dc 4 to 15 V dc	2 floating changeover contacts	17 to 35 V dc 35 to 72 V dc	<ul style="list-style-type: none"> • Electrical isolation of input, supply voltage and outputs • KRS 12K: Contact circuit with 2 x 100 kΩ or 2 x 47 kΩ
KVF 11	1 x 24 V dc	Logical output 24 V dc, 1.5 A short-circuit-proof 1 floating changeover contact for error signal output	24 V dc	<ul style="list-style-type: none"> • Output voltage = supply voltage • Electrical isolation of input and output • Fuse on output voltage • Undervoltage monitoring of output • Wire break and short circuit monitoring • Variable circuit of error signal output • Command simulation with test probe

Coupler KRB 11



Coupler KRB 11

Features

- Input voltage = supply voltage
- Electrical isolation of control and load circuits
- Floating command input with LED status indication
- Floating changeover contact

Function

A relay is energized as soon as the supply voltage is connected. The relay's changeover contact provides a floating signal at the relay output.

Output circuit and control circuit are safely isolated in compliance with DIN VDE 0106 Part 101 (4kV/2). An LED indicates the presence of the input voltage.

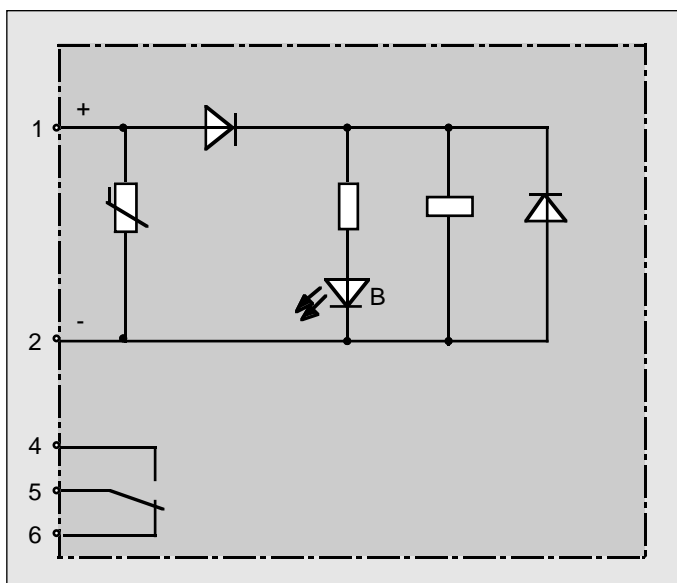

Block diagram KRB 11: Direct voltage variants

Technical Characteristics

Electrical data

Input voltage V_{supply}
(= supply voltage) 230 V ac, 60 V ac, 48 V ac,
24 V ac, 125 V dc, 110 V dc,
60 V dc, 48 V dc, 24 V dc

Voltage tolerance - 15 %, + 10 %

'1' signal 0.85 to 1.1 V_{supply}

'0' signal < 0.2 V_{supply}

Power consumption at V_{supply}

230 V ac:	20 mA
60 V ac:	19 mA
48 V ac:	15 mA
24 V ac:	21 mA
125 V dc, 110 V dc:	5 mA
60 V dc:	4 mA
48 V dc:	6 mA
24 V dc:	17 mA

Output 1 floating changeover contact

Contact material AgCdO

Max. switching current 8 A

Max. switching voltage AC: 250 V, DC: 300 V

Max. switching capacity AC: 2000 VA,
DC: 50 W to 270 W

Limit continuous current 8 A

Recommended for loads > 500 mA, 12 V

Switching performance
acc. to DIN VDE 0660
Part 200

AC 15: 230 V, 12 A (On)/
1.2 A (Off), $\cos \varphi = 0.7/0.4$
 $3 \cdot 10^5$ switching cycles min.
DC 13: 24 V/2 A/ $\tau = 300$ ms:
 10^5 switching cycles min.
24 V/2 A/ $\tau = 50$ ms:
 $1.5 \cdot 10^5$ switching cycles min.

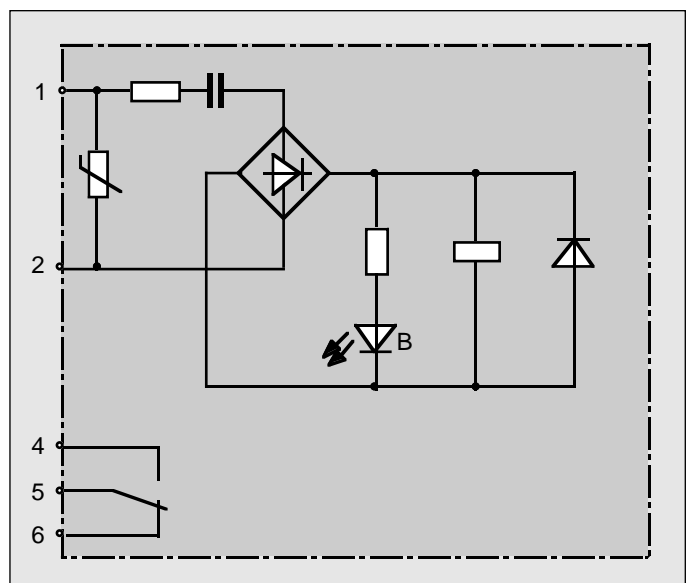

Block diagram KRB 11: Alternating voltage variants

Ambient conditions

Temperature ranges	
Operation	- 10 °C to + 50 °C
Storage	- 25 °C to + 55 °C
Transport	- 25 °C to + 70 °C
Relative air humidity	Yearly mean humidity \leq 75 % \leq 95 % for 30 days at 30 °C

Safety parameters

Insulation coordination acc. to DIN VDE 0110	Overvoltage category III Contamination degree 2
Insulation resistance (test voltage) between control section and output contact	4 kV _{eff} /1 s
Safe isolation DIN 0106 Part 101 and EN 61010-1	Double or reinforced insulation between control and load circuit Overvoltage category II Contamination degree 2 Max. operating voltage: 250 V ac

Mechanical data

Enclosure	Add-on enclosure 22.5 mm x 78 mm x 91 mm without wire clamps see dimension drawing page 24
Mounting	Fitted on standard rail DIN EN 50022, 35 mm width

Protection class DIN 40050 and IEC 529	Enclosure IP 40 Terminals IP 20
---	------------------------------------

Shock protection acc. to DIN VDE 0106 Part 100

Mechanical stability IEC 68-2-6 IEC 68-2-29	2 g / 0.15 mm / 10Hz to 150Hz 15 g/6 ms
---	--

Maximum wire cross section	2 x 1.5 mm ² single core 1 x 2.5 mm ² single core 2 x 1.5 mm ² fine wire with connector sleeve to DIN 46228
-------------------------------	---

Burning behaviour	self-extinguishing VO acc. to UL 94, IEC 707
-------------------	---

Weight	200 g approx.
--------	---------------

Order Details Coupler KRB 11

Order number	31 - 95 - 0 _ _
Supply voltage	
230 V ac	10
60 V ac	13
48 V ac	14
24 V ac	15
125 V dc	31
110 V dc	32
60 V dc	33
48 V dc	34
24 V dc	35

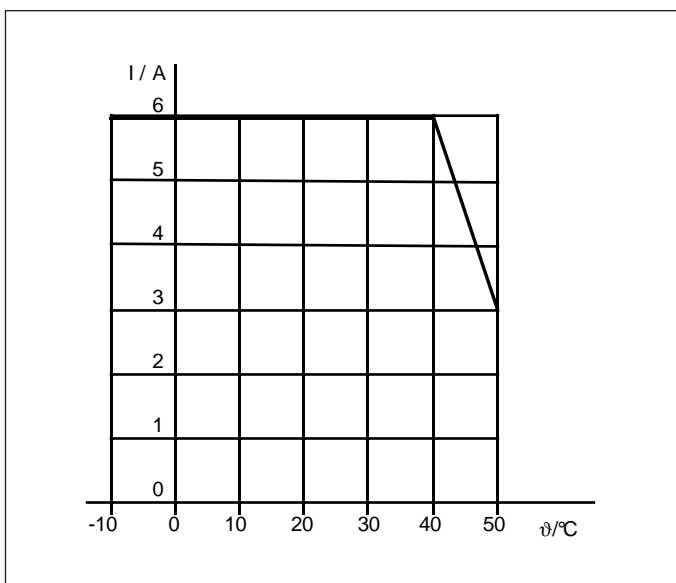

Coupler KRB 11: Limit curve for continuous current

Coupler KRB 12



Coupler KRB 12

Features

- Input voltage = supply voltage
- Electrical isolation of control and load circuits
- Floating command input with LED status indication
- 2 floating NO contacts

Function

Two relays are energized as soon as the supply voltage is connected.

Each relay provides a floating NO contact at its output.

The outputs are safely isolated from each other as well as from the control circuit in compliance with DIN VDE 0106 Part 101 (4kV/2). An LED indicates the presence of the input voltage.

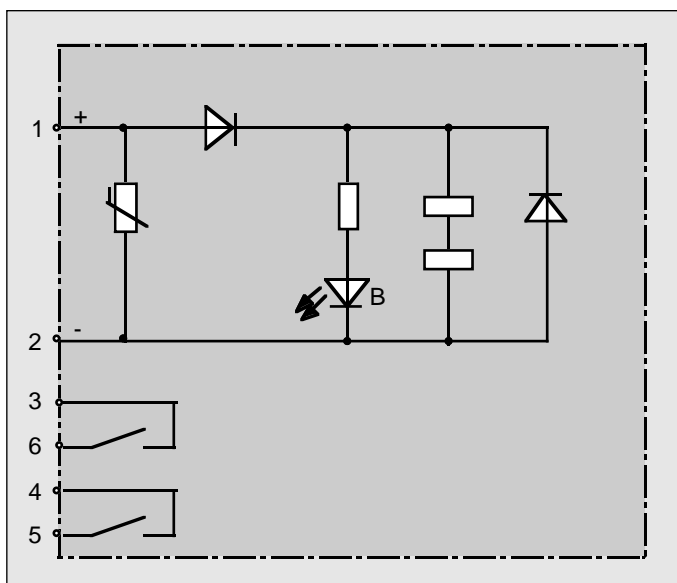

Block diagram KRB 12: Direct voltage variants

Technical Characteristics

Electrical data

Input voltage V_{supply}
(= supply voltage) 230 V ac, 60 V ac, 48 V ac,
24 V ac, 125 V dc, 110 V dc,
60 V dc, 48 V dc, 24 V dc

Voltage tolerance - 15 %, + 10 %

'1' signal 0.85 to 1.1 V_{supply}

'0' signal < 0.2 V_{supply}

Power consumption at V_s

230 V ac:	20 mA
60 V ac:	16 mA
48 V ac:	15 mA
24 V ac:	31 mA
125 V dc, 110 V dc:	7 mA
60 V dc:	14 mA
48 V dc:	17 mA
24 V dc:	34 mA

Output 2 floating NO contacts

Contact material AgCdO

Max. switching current 8 A

Max. switching voltage AC: 250 V, DC: 300 V

Max. switching capacity AC: 2000 VA,
DC: 50 W to 270 W

Limit continuous current 8 A

Recommended for loads > 500 mA, 12 V

Switching performance
acc. to DIN VDE 0660
Part 200

AC 15: 230 V, 12 A (On)/
1.2 A (Off), $\cos \varphi = 0.7/0.4$
 $3 \cdot 10^5$ switching cycles min.
DC 13: 24 V/2 A/ $\tau = 300$ ms:
 10^5 switching cycles min.
24 V/2 A/ $\tau = 50$ ms:
 $1.5 \cdot 10^5$ switching cycles min.

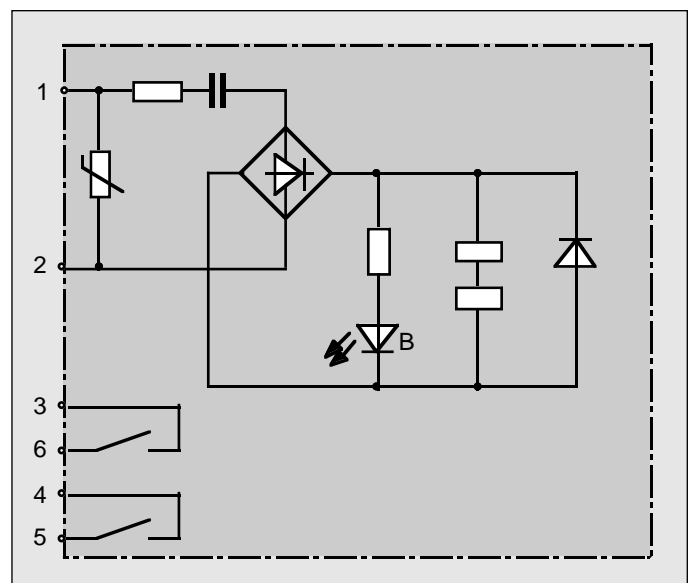

Block diagram KRB 12: Alternating voltage variants

Ambient conditions

Temperature ranges	
Operation	- 10 °C to + 50 °C
Storage	- 25 °C to + 55 °C
Transport	- 25 °C to + 70 °C
Relative air humidity	Yearly mean humidity \leq 75 % \leq 95 % for 30 days at 30 °C

Safety parameters

Insulation coordination acc. to DIN VDE 0110	Overvoltage category III Contamination degree 2
Safe isolation DIN 0106 Part 101 EN 61010-1	Double or reinforced insulation between control and load circuits Overvoltage category II Contamination degree 2 Max. operating voltage: 250 V ac

Insulation resistance (test voltage) between control section and output contact	4 kV _{eff} /1 s
between outputs	4 kV _{eff} /1 s

Mechanical data

Enclosure	Add-on enclosure 22.5 mm x 78 mm x 91 mm without wire clamps see dimension drawing page 24
Mounting	Fitted on standard rail DIN EN 50022, 35 mm width

Protection class DIN 40050 and IEC 529	Enclosure IP 40 Terminals IP 20
---	------------------------------------

Shock protection acc. to DIN VDE 0106 Part 100

Mechanical stability IEC 68-2-6	2 g / 0.15 mm / 10Hz to 150Hz
IEC 68-2-29	15 g/6 ms

Maximum wire cross section	2 x 1.5 mm ² single core 1 x 2.5 mm ² single core 2 x 1.5 mm ² fine wire with connector sleeve to DIN 46228
-------------------------------	---

Burning behaviour	self-extinguishing VO to UL 94, IEC 707
-------------------	--

Weight	200 g approx.
--------	---------------

Order Details Coupler KRB 12

Order number	31 - 95 - 0 _ _
Supply voltage	
230 V ac	20
60 V ac	23
48 V ac	24
24 V ac	25
125 V dc	41
110 V dc	42
60 V dc	43
48 V dc	44
24 V dc	45

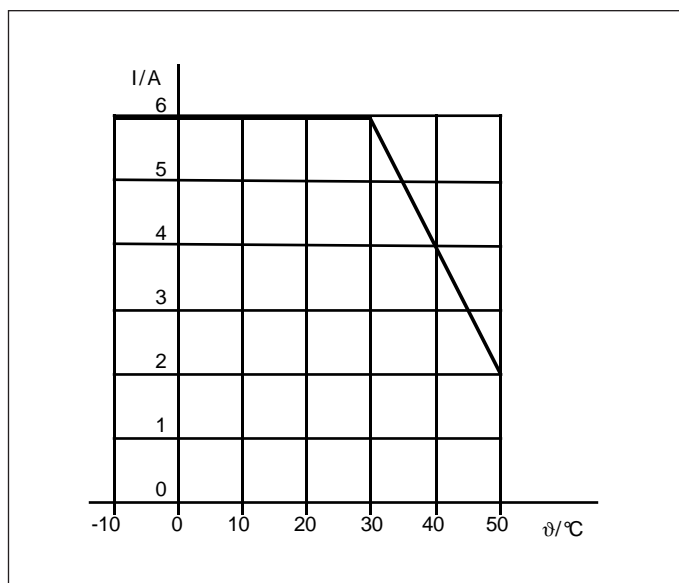

Coupler KRB 12: Limit curve for continuous current

Couplers KRC 12 and KRC 12A



Couplers KRC 12 and KRC 12A

Features

- Output voltage = supply voltage
- Electrical isolation of input and output
- Single pole fuse (KRC 12A: 2-pole fuse)
- Output monitored for undervoltage
- Output shutdown and error signal output on failure
- Resistances for the output circuit of the error signal contact (option)
- Command simulation with test probe

Function

The voltage for the load circuit is connected to the bipolar output terminals as soon as the input signal is applied.

The common power supply for the load circuit and the coupler's internal supply voltage is fuse-protected (single-pole fuse for the KRC 12 and double-pole fuse for the KRC 12A coupler). The fuses are accessible at the front panel.

A normally-closed circuit is used for undervoltage monitoring: if the voltage drops below a specific value, the load circuit is shut down and the alarm relay is de-energized. The contacts of this relay are electrically isolated from all other parts of the circuit.

For test purposes the output relay can be driven directly using a test probe. There must be no response from the undervoltage monitoring circuit in this case.

Technical Characteristics

Electrical data

Supply voltage V_{supply}	KRC 12: 24 V dc ; 60 V dc KRC 12A: 48 V dc		
Voltage tolerance	$\pm 20\%$		
Power consumption	V_{supply}	'1' signal	'0' signal
	24 V	32 mA	21 mA
	48 V	19 mA	11 mA
	60 V	20 mA	13 mA
Input voltage	13 V dc to 72 V dc		
'1' signal	$< 5\text{ V } \text{dc}$		
'0' signal	$< 5\text{ V } \text{dc}$		
Input current	5 mA approx.		

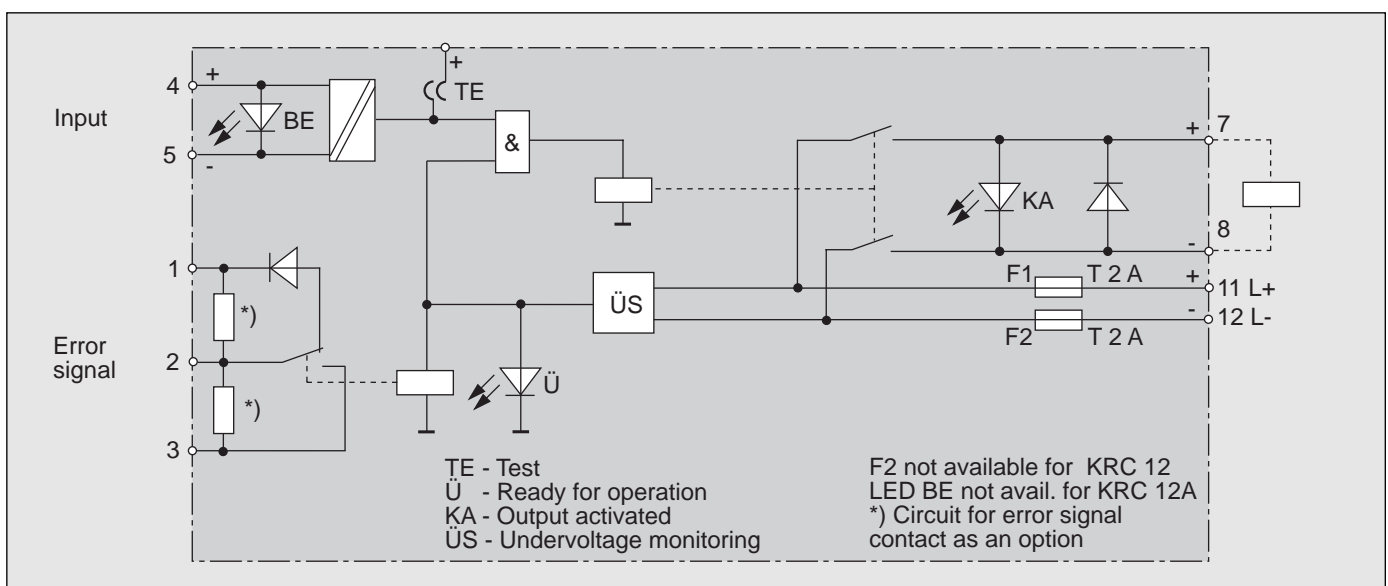

Block diagram KRC 12 and KRC 12A

Output	2 NO contacts	Protection class	Enclosure IP 40
Output voltage	Supply voltage - 1 V	DIN 40050 and IEC 529	Terminals IP 20
Max. output power	35 W at $V_{\text{supply}} = 24 \text{ V}$ 75 W at $V_{\text{supply}} = 48 \text{ V}$ 60 W at $V_{\text{supply}} = 60 \text{ V}$	Shock protection acc. to DIN VDE 0106 Part 100	
Max. output current	1.5 A at $V_{\text{supply}} = 24 \text{ V}$, 48 V 1.0 A at $V_{\text{supply}} = 60 \text{ V}$	Mechanical stability	2 g / 0.15 mm / 10 Hz to 150 Hz 15 g / 6 ms
Fusing	KRC 12 : 1 x T 2 A KRC 12A: 2 x T 2 A	Maximum wire cross section	2 x 1.5 mm ² single core 1 x 2.5 mm ² single core 2 x 1.5 mm ² fine wire with connector sleeve to DIN 46228
Error signal	1 floating changeover contact	Burning behaviour	self-extinguishing according to UL 94, IEC 707
Contact material	AgNi 0.15 gold-plated	Weight	160 g approx.
Max. output current	1 A		
Recommended for loads	> 1 mA, 6 V dc		
Threshold value for undervoltage monitoring	15 V to 18 V at $V_{\text{supply}} = 24 \text{ V}$ 32 V to 35 V at $V_{\text{supply}} = 48 \text{ V}$ 44 V to 48 V at $V_{\text{supply}} = 60 \text{ V}$		

Ambient conditions

Temperature ranges	
Operation	- 10 °C to + 50 °C
Storage	- 25 °C to + 55 °C
Transport	- 25 °C to + 70 °C
Relative air humidity	Yearly mean humidity ≤ 75 % ≤ 95 % for 30 days at 30 °C

Safety parameters

Insulation coordination acc. to DIN VDE 0110	Overvoltage category III Contamination degree 2
Safe isolation DIN 0106 Part 101 EN 61010-1	Double or reinforced insulation between control and load circuits Overvoltage category II Contamination degree 2 Max. operating voltage: 250 V ac

Insulation resistance (test voltage) between control section and output contact

4 kV_{eff} / 1 s

between error signal output and all other circuit parts

4 kV_{eff} / 1 s

Mechanical data

Enclosure	Add-on enclosure 22.5 mm x 78 mm x 110 mm without wire clamps see dimension drawing page 24
Mounting	Fitted on standard rail DIN EN 50022, 35 mm width

Order Details

Coupler KRC 12

Order number	Supply voltage	
		31 - 95 - 0 _ _
None	24 V dc	60
None	60 V dc	61
2 x 100 kΩ	24 V dc	63
2 x 100 kΩ	60 V dc	64
2 x 47 kΩ	24 V dc	66
2 x 47 kΩ	60 V dc	67

Order Details

Coupler KRC 12A

Order number	Supply voltage	
		31 - 95 - 0 _ _
None	48 V dc	62
2 x 100 kΩ	48 V dc	65
2 x 47 kΩ	48 V dc	68

Couplers KRD 22 and KRD 22S



Couplers KRD 22 and KRD 22S

Features

- Input voltage = supply voltage
- 2 inputs with LED status indication
- Output: 2 changeover contacts with common reference
- KRD 22S: Simulation of input signals with test probe at a signalling-circuit voltage of 24 Vdc

Function

The KRD 22 coupler consists of two relays which can be driven separately. The respective input signal is also the supply voltage for the relay. An LED indicates the switching state of the relays.

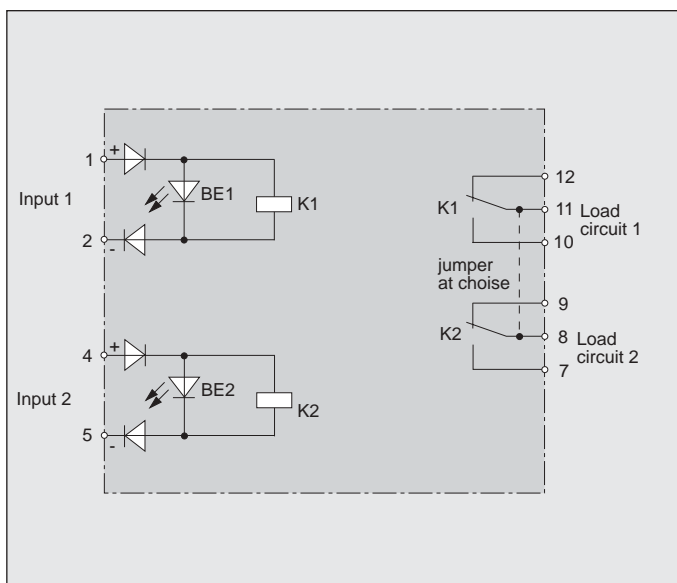

Block diagramm KRD 22

The output is provided by two floating changeover contacts with common root.

The KRD 22S coupler additionally allows the simulation of both input signals at a signalling voltage of 24 Vdc. Using a test probe and socket-contact, each relay can be controlled directly.

The signalling voltage and the input signals are decoupled by means of diodes and have the same reference potential.

Technical Characteristics

Electrical data

Input voltage (= supply voltage V_{supply})	24 Vdc, 60 Vdc
Voltage tolerance	$\pm 20\%$
'1' signal	0.8 to 1.2 V_{supply}
'0' signal	$< 0.2 V_{\text{supply}}$
Input current at '1' signal = 24 Vdc at '1' signal = 60 Vdc	approx. 20 mA for each input approx. 8 mA for each input
Output	2 floating changeover contacts with common reference
Contact material	AgCdO
Max. switching current	8 A
Max. switching voltage	AC: 250 V, DC: 300 V
Max. switching capacity	AC: 2000 VA, DC: 50 W to 270 W
Limit continuous current	8 A
Recommended for loads	$> 500 \text{ mA}$, 12 V

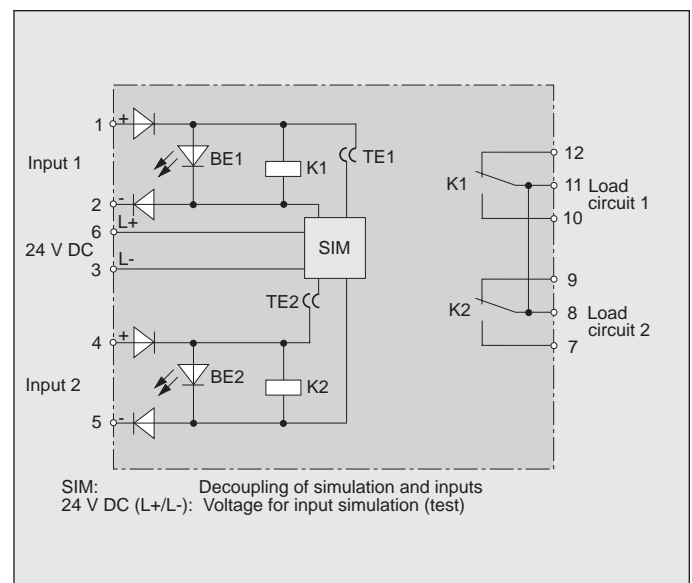

Block diagramm KRD 22S

Switching performance
acc. to DIN VDE 0660
Part 200

AC 15: 230 V, 12 A (On) /
1.2 A (Off), $\cos \varphi = 0.7/0,4$
 3×10^5 switching cycles min.
DC 13: $24 \text{ V}/2 \text{ A}/\tau = 300 \text{ ms}$:
 1×10^5 switching cycles min.
 $24 \text{ V}/2 \text{ A}/\tau = 50 \text{ ms}$:
 1.5×10^5 switching cycles min.

Ambient conditions

Temperature ranges

Operation

Storage

Transport

Relative air humidity

- 10 °C to + 50 °C

- 25 °C to + 55 °C

- 25 °C to + 70 °C

Yearly mean humidity $\leq 75\%$
 $\leq 95\%$ for 30 days at 30 °C

Safety parameters

Insulation coordination
acc. to DIN VDE 0110

Safe isolation

DIN 0106 Part 101

EN 61010-1

Overtoltage category III
Contamination degree 2

Double or reinforced insulation
between control and load
circuits

Overtoltage category II

Contamination degree 2

Max. operating voltage: 250 Vac

Insulation resistance
(test voltage) between error signal
output and all other parts of the
circuit

$4 \text{ kV}_{\text{eff}}/1 \text{ s}$

Mechanical data

Enclosure

Add-on enclosure
22.5 mm x 78 mm x 110 mm
without wire clamps
see dimension drawing page 24

Mounting

Fitted on standard rail
DIN EN 50022, 35 mm width

Protection class
DIN 40050 and IEC 529

Enclosure IP 40
Terminals IP 20

Shock protection acc. to DIN VDE 0106 Part 100

Mechanical stability

IEC 68-2-6

IEC 68-2-29

$2 \text{ g}/0.15 \text{ mm}/10 \text{ Hz}$ to 150 Hz
15 g/6 ms

Maximum

wire cross section

$2 \times 1.5 \text{ mm}^2$ single core
 $1 \times 2.5 \text{ mm}^2$ single core
 $2 \times 1.5 \text{ mm}^2$ fine wire with
connector sleeve to DIN 46228

Burning behaviour

self-extinguishing
according to UL 94, IEC 707

Weight

160 g approx.

Order Details

Coupler KRD 22

Order number

31 - 95 - 0 _ _

Supply voltage

24Vdc

60Vdc

70

75

Order Details

Coupler KRD 22S

Order number

31 - 95 - 071

Supply voltage

24Vdc

Coupler KRD 22U



Coupler KRD 22U

Features

- Input voltage = supply voltage
- 2 inputs with LED status indication
- Output: 2 changeover contacts with common reference
- Simulation of input signals with test probe at 24 V dc signalling voltage
- Undervoltage monitoring of a 230 V ac external supply
- Error signal

Function

The KRD 22U coupler consists of two relays which can be operated separately. The respective input signal is also the supply voltage for the relay. An LED indicates the switching state of the relays.

The output is provided by two floating changeover contacts with common root.

The coupler allows the simulation of both input signals at a signalling voltage of 24 V dc.

Using a test probe and socket-contact, each relay can be controlled directly.

The signalling voltage and the input signals are decoupled by means of diodes and have the same reference potential.

The coupler is provided with a circuit for the undervoltage monitoring of an external 230 V supply. The LED display „P“ indicates the presence of this voltage.

If the voltage drops below the permissible limit value, the alarm relay is de-energized. The error signal is then issued via the relay's changeover contact. The common reference of the error signal contact is connected to the L+ terminal of the signalling voltage (terminal 6) and terminal 11.

The LED display „Ü“ remains illuminated (ready for operation) as long as the undervoltage relay has not tripped and the signalling-voltage for the simulation is present.

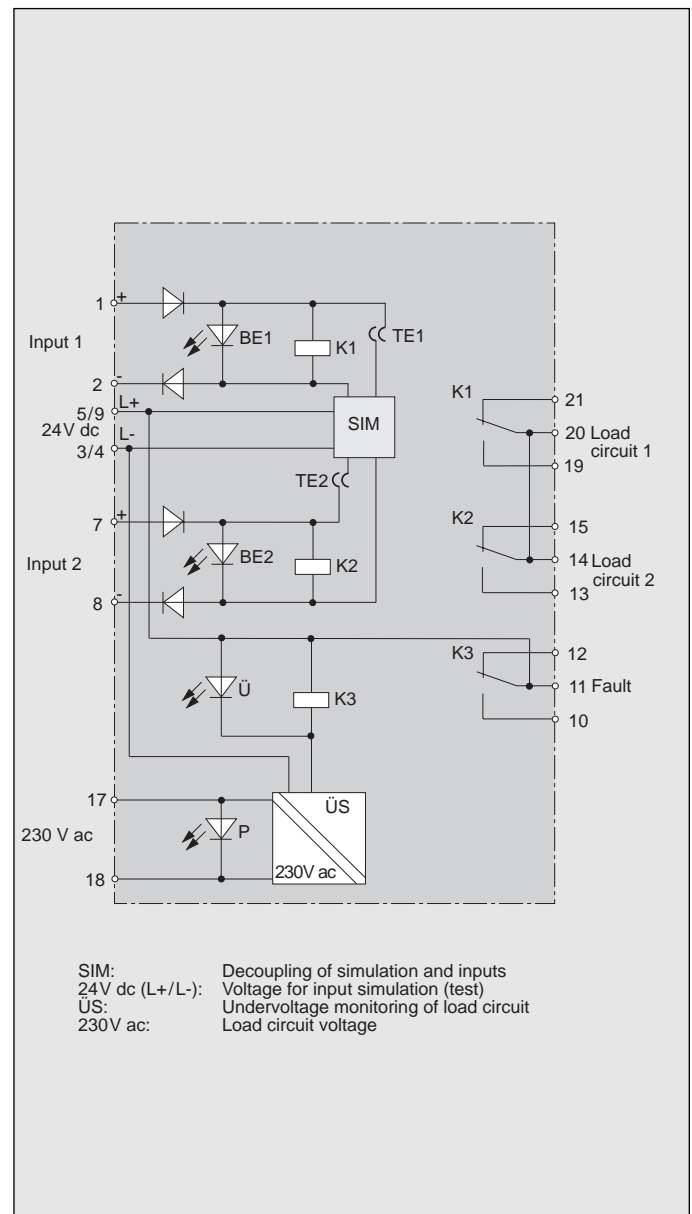

Block diagram KRD 22U

Technical Characteristics

Electrical data

Input voltage (= supply voltage V_{supply})	24 V dc, 60 V dc
Voltage tolerance	$\pm 20\%$
'1' signal	0.8 to 1.2 V_{supply}
'0' signal	$< 0.2 V_{\text{supply}}$
Input current at '1' signal = 24 V dc	approx. 20 mA for each input
Output	2 floating changeover contacts with common reference
Contact material	AgCdO
Max. switching current	8 A
Max. switching voltage	AC: 250 V, DC: 300 V
Max. switching capacity	AC: 2000 VA, DC: 50 W to 270 W
Limiting continuous current	8 A
Recommended for loads	> 500 mA, 12 V
Switching performance acc. to VDE 0660 Part 200	AC 15: 230 V, 12 A (On)/ 1.2 A (Off), $\cos \varphi = 0.7/0.4$ $3 \cdot 10^5$ switching cycles min. DC 13: $24 \text{ V} / 2 \text{ A} / \tau = 300 \text{ ms}$: 10^5 switching cycles min. $24 \text{ V} / 2 \text{ A} / \tau = 50 \text{ ms}$: $1.5 \cdot 10^5$ switching cycles min.
Error signal	1 changeover contact, common reference wired to terminals 6 and 11
Contact material	AgNi 0.15 gold-plated
Max. output current	1 A
Recommended for loads	> 1 mA, 6 V dc
Threshold value of undervoltage monitoring	165 V ac to 185 V ac
Power consumption	approx. 4.4 mA, 8 mA max.

Ambient conditions

Temperature ranges	
Operation	- 10 °C to + 50 °C
Storage	- 25 °C to + 55 °C
Transport	- 25 °C to + 70 °C
Relative air humidity	Yearly mean humidity $\leq 75\%$ $\leq 95\%$ for 30 days at 30 °C

Safety parameters

Insulation coordination acc. to DIN VDE 0110	Overvoltage category III Contamination degree 2
Safe isolation DIN 0106 Part 101 EN 61010-1	Double or reinforced insulation between control and load circuits Overvoltage category II Contamination degree 2 Max. operating voltage: 250 V ac
Insulation resistance (test voltage) between error signal output and all other circuit parts	$4 \text{ kV}_{\text{eff}} / 1 \text{ s}$

Mechanical data

Enclosure	Add-on enclosure 22.5 mm x 78 mm x 110 mm without wire clamps see dimension drawing page 24
Mounting	Fitted on standard rail DIN EN 50022, 35 mm width
Protection class	Enclosure IP 40 Terminals IP 20
Shock protection acc. to DIN VDE 0106 Part 100	
Mechanical stability	
IEC 68-2-6	2 g / 0.15 mm / 10 Hz to 150 Hz
IEC 68-2-29	15 g / 6 ms
Maximum wire cross section	2 x 1.5 mm ² single core 1 x 2.5 mm ² single core 2 x 1.5 mm ² fine wire with connector sleeve to DIN 46228
Burning behaviour	self-extinguishing according to UL 94, IEC 707
Weight	200 g approx.

Order Details

Coupler KRD 22U

Order number	31 - 95 - 072
Supply voltage	24 V dc

Couplers KRE 12, KRE 24 and KRE 24A



Couplers KRE 12, KRE 24 and KRE 24A

Features

KRE 12:

- Relay with blowout magnet for high direct-current loads

KRE 24:

- Double command output
- 2 relays with blowout magnet for high direct-current loads

KRE 24A:

- Double command output
- 2 relays with blowout magnet for high direct-current loads
- One parallel relay for each relay
NC contacts of the supplementary relays connected in series

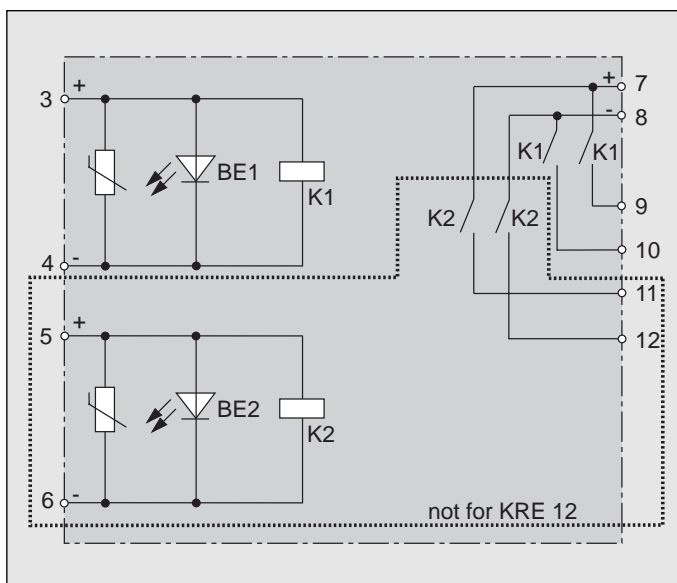

Block diagram KRE 12 and KRE 24

Function

Upon application of the input signal to terminals 3 (L+) and 4 a relay K1 is energized and the voltage present at terminals 7 (L+) and 8 is connected to terminals 9 (L+) and 10 (bipolar). If an additional input voltage is applied to terminals 5 (L+) and 6, a second relay K2 is energized and the voltage present at terminals 7 (L+) and 8 is connected to terminals 11 (L+) and 12 (bipolar). This function is not available for the KRE 12 coupler.

When applying direct current, it is essential to observe the preset polarity at the contact outputs to ensure the operation of the blowout magnet.

The KRE 24A coupler contains two supplementary relays K3 and K4 which are connected in parallel with relays K1 and K2, respectively. The NC contacts (floating) of the relays K3 and K4 are connected in series and led to terminals 1 and 2.

Technical Characteristics

Electrical data

Supply voltage V_{supply}	24 V dc, 60 V dc
Voltage tolerance	-15 % to + 10 %
'1' signal	0.85 to 1.1 V_{supply}
'0' signal	< 0.2 V_{supply}
Power consumption	KRE 12 24 V dc 43 mA
	60 V dc 23 mA
	KRE 24 24 V dc 2 x 43 mA
	60 V dc 2 x 23 mA
	KRE 24A 24 V dc 2 x 54 mA
	60 V dc 2 x 27 mA

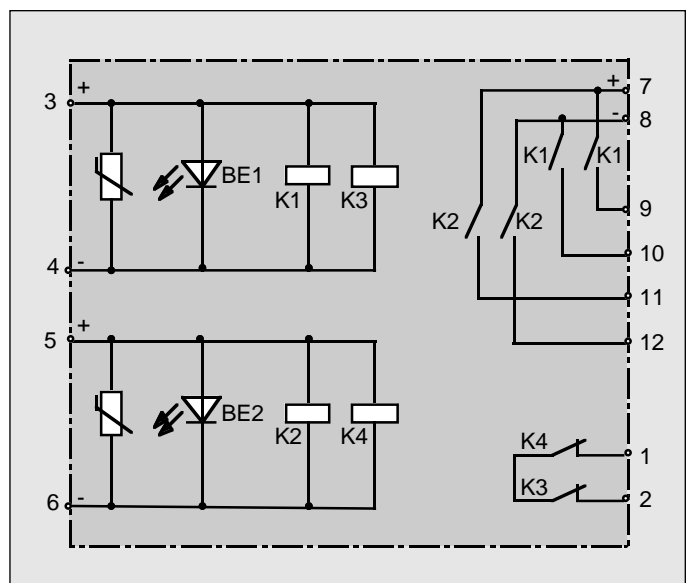

Block diagram KRE 24A

Outputs	2 x 2 NO contacts KRE 12: 2 NO contacts
Contact material	Silver alloy
Max. switching voltage	250 V ac, 300 V dc
Max. switching current	5 A
Short-circuit current for 0.5 s	30 A
Continuous thermal current	5 A
Max. breaking capacity	at ohmic load: 4 A, 250 V dc (electric arc < 3 ms)
at cos φ = 1	5 A, 250 V ac
at cos φ = 0.4:	3 A, 250 V ac
Response time at rated value of supply voltage	15 ms
Supplementary output KRE 24A	Series connection of one of the NC contacts of relays K3 and K4
Contact material	AgNi 0.15 gold-plated
Recommended for loads	> 1 mA, 6 V dc

Ambient conditions

Temperature ranges	
Operation	- 10 °C to + 50 °C
Storage	- 25 °C to + 55 °C
Transport	- 25 °C to + 70 °C
Relative air humidity	Annual mean humidity ≤ 75 % ≤ 95 % for 30 days at 30 °C

Safety parameters

Insulation coordination acc. to DIN VDE 0110	Overvoltage category III Contamination degree 2
Safe isolation DIN 0106 Part 101	Double or reinforced insulation between control and load circuits
EN 61010-1	Overvoltage category II Contamination degree 2 Max. operating voltage: 250 V ac
KRE 24A: Safe isolation DIN 0106 Part 101 EN 61010-1	Double or reinforced insulation between supplementary output and other outputs Overvoltage category II Contamination degree 2 Max. operating voltage: 250 V ac
Insulation resistance (test voltage) between control section and output contact	4 kV _{eff} / 1 s
KRE 24A: between supplementary output and other outputs	4 kV _{eff} / 1 s

Mechanical data

Enclosure	Add-on enclosure 22.5 mm x 78 mm x 91 mm without wire clamps see dimension drawing page 24
Mounting	Fitted on standard rail DIN EN 50022, 35 mm width
Protection class	Enclosure IP 40 Terminals IP 20
DIN 40050 and IEC 529	
Shock protection acc. to DIN VDE 0106 Part 100	
Mechanical stability	
IEC 68-2-6	2 g / 0.15 mm / 10 Hz to 150 Hz
IEC 68-2-29	15 g / 6 ms
Maximum wire cross section	2 x 1.5 mm ² single core 1 x 2.5 mm ² single core 2 x 1.5 mm ² fine wire with connector sleeve to DIN 46228
Burning behaviour	self-extinguishing according to UL 94, IEC 707
Weight	
KRE 12, KRE 24	200 g approx.
KRE 24A	250 g approx.

Order Details

Coupler KRE 12

Order number	31 - 95 - 1 _ _
Supply voltage	
60 V dc	00
24 V dc	01

Order Details

Coupler KRE 24

Order number	31 - 95 - 0 _ _
Supply voltage	
60 V dc	96
24 V dc	97

Order Details

Coupler KRE 24A

Order number	31 - 95 - 0 _ _
Supply voltage	
60 V dc	98
24 V dc	99

Couplers KRS 12 and KRS 12K



Couplers KRS 12 and KRS 12K

Features

- Electrical isolation of input, supply voltage and outputs
- 2 floating changeover contacts
- Contact circuit with resistors for KRS 12K

Function

A '1' signal at the input triggers two series-connected relays. Two floating changeover contacts are available as output.

KRS 12K couplers: a resistor is connected in parallel to the NC / NO contact of one changeover contact.

A LED indicates the switching state of the relays.

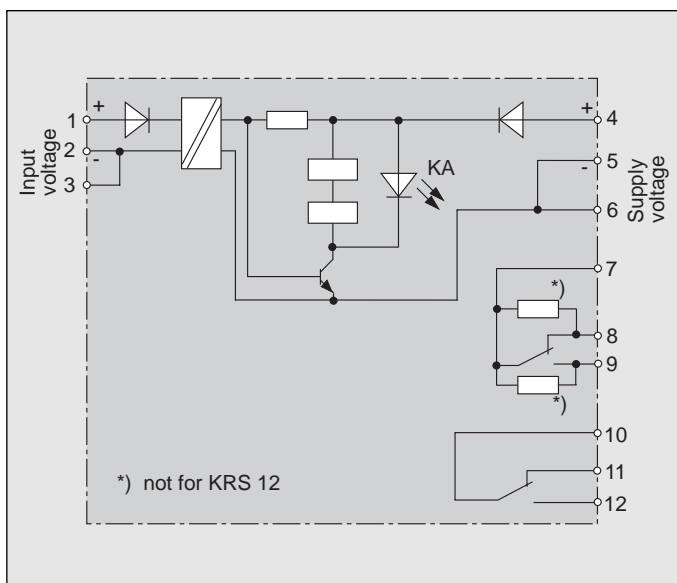

Block diagram KRS 12 and KRS 12A

Technical Characteristics

Electrical data

Supply voltage V_{supply}	17 V to 35 V dc 35 V to 72 V dc
Power consumption	$V_{\text{supply}} = 24 \text{ V}$: 24 mA approx. $V_{\text{supply}} = 48 \text{ V}$: 15 mA approx. $V_{\text{supply}} = 60 \text{ V}$: 17 mA approx.
Input (see also Order Details)	
'1' signal	13 V to 72 V dc 4 V to 15 V dc
'0' signal	< 5 V dc < 2 V dc
Input current at '1' signal	2.5 mA approx.
Output	2 changeover contacts, simultaneously operated; KRS 12K: resistors connected in parallel with one changeover contact
Contact material	AgNi 0.15 gold-plated
Max. switching voltage	250 V ac, 300 V dc
Max. switching current	8 A
Limit continuous current	6 A
Max. switching capacity	2000 VA, 50 W to 270 W
Recommended for loads	> 1 mA, 6 V dc

Ambient conditions

Temperature ranges	
Operation	- 10 °C to + 50 °C
Storage	- 25 °C to + 55 °C
Transport	- 25 °C to + 70 °C
Relative air humidity	Annual mean humidity $\leq 75\%$ $\leq 95\%$ for 30 days at 30 °C

Safety parameters

Insulation coordination acc. to DIN VDE 0110	Overvoltage category III Contamination degree 2
Insulation resistance between control section and output contact	4 kV _{eff} /1 s
between outputs	4 kV _{eff} /1 s
between input and supply voltage	4 kV _{eff} /1 s

Mechanical data

Enclosure	Add-on enclosure 22.5 mm x 78 mm x 110 mm without wire clamps see dimension drawing page 24
Mounting	Fitted on standard rail DIN EN 50022, 35 mm width
Protection class DIN 40050 and IEC 529	Enclosure IP 40 Terminals IP 20
Shock protection acc. to DIN VDE 0106 Part 100	
Mechanical stability IEC 68-2-6 IEC 68-2-29	2 g / 0.15 mm / 10 Hz to 150 Hz 15 g/6 ms
Maximum wire cross section	2 x 1.5 mm ² single core 1 x 2.5 mm ² single core 2 x 1.5 mm ² fine wire with connector sleeve to DIN 46228
Burning behaviour	self-extinguishing according to UL 94, IEC 707
Weight	150 g approx.

Order Details

Coupler KRS 12

Order number	31 - 95 - 1 _ _		
Input (‘1’ signal)	Supply voltage		
13 V to 72 V	17 V to 35 V		20
13 V to 72 V	35 V to 72 V		21
4 V to 15 V	17 V to 35 V		22
4 V to 15 V	35 V to 72 V		23

Order Details

Coupler KRS 12K

Order number	31 - 95 - 1 _ _		
Contact circuit	Input (‘1’ signal)	Supply voltage	
2 x 100 kΩ	13 V to 72 V	17 V to 35 V	24
2 x 100 kΩ	13 V to 72 V	35 V to 72 V	25
2 x 100 kΩ	4 V to 15 V	17 V to 35 V	26
2 x 100 kΩ	4 V to 15 V	35 V to 72 V	27
2 x 47 kΩ	13 V to 72 V	17 V to 35 V	28
2 x 47 kΩ	13 V to 72 V	35 V to 72 V	29
2 x 47 kΩ	4 V to 15 V	17 V to 35 V	30
2 x 47 kΩ	4 V to 15 V	35 V to 72 V	31

Coupler KVF 11



Coupler KVF 11

Function

When the input signal is present, a transistor connects the output voltage to terminals 7 (L+) and 8.

The common power supply for the load circuit and the coupler's internal supply voltage is protected by a single pole fuse and monitored for undervoltage.

The alarm relay is de-energized if the supply voltage drops below the value of $\leq 18\text{ V}$. The floating changeover contact of this relay is taken to terminals; a diode is connected in series with the NC contact. The contacts of the alarm relay are electrically isolated from all other parts of the circuit.

The alarm relay is also de-energized if an overload or short-circuit fault or a wire break is detected in the load circuit.

When the short circuit or overload conditions have been eliminated, the load circuit is automatically reconnected provided that the input signal is present.

If the supply voltage falls below 11 V the load circuit is switched off. It can only be reconnected when the supply voltage has reached a value that is in the permitted tolerance range.

For test purposes the output relay can be operated directly using a test probe.

Features

- Output voltage = supply voltage
- Electrical isolation of input and output
- Fuse on output voltage
- Undervoltage monitoring of output
- Short circuit and wire break monitoring
- Command simulation with test probe
- Resistance circuit for error signal contact

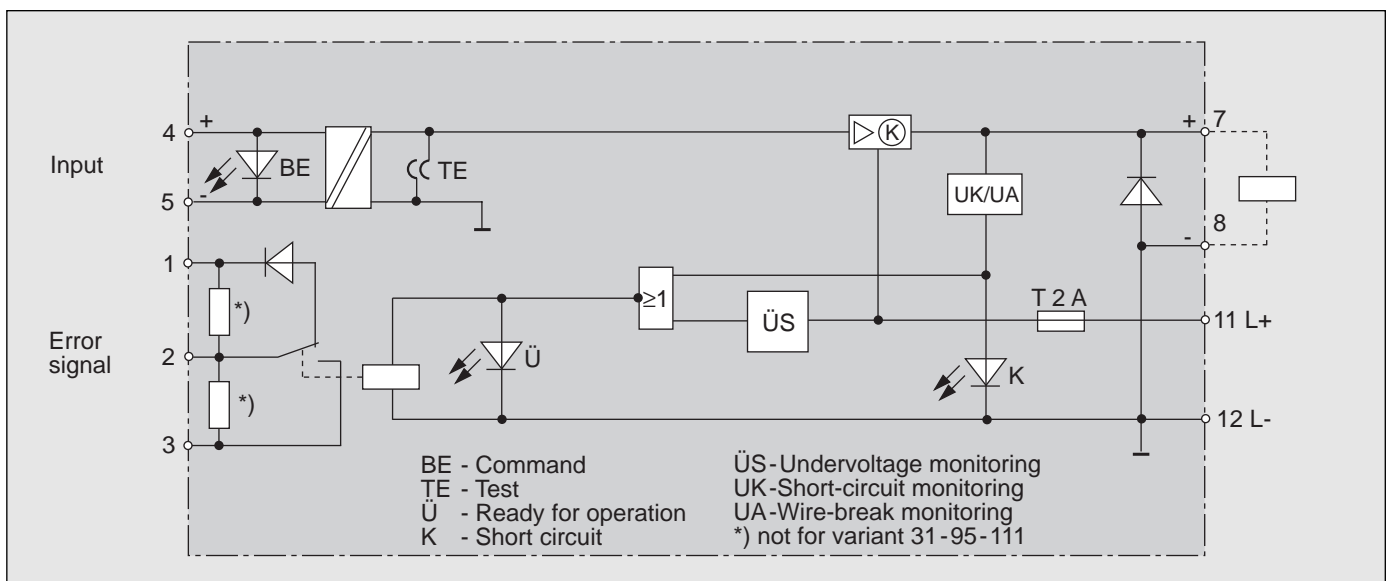

Block diagram KVF 11

Technical Characteristics

Electrical data

Supply voltage V_{supply}	24 V dc
Voltage tolerance	$\pm 20\%$
Power consumption at reference conditions without load	25 mA approx.
'1' signal	13 V to 72 V dc
'0' signal	< 5 V dc
Input current at '1' signal	5 mA approx.
Output voltage	Supply voltage - 0.6 V
Max. output power $P_{\text{outputmax}}$	35 W
Max. output current	1.5 A
Load circuit shutdown if supply voltage overload	$V_{\text{Supply}} < 11\text{ V}$ $P_{\text{outputmax}} > 35\text{ W}$
Error signal	1 changeover contact, floating NC contact via diode to terminal 1
Error signal circuit variants 31-95-110	2 resistors, each 100 k Ω
31-95-112	2 resistors, each 47 k Ω
Contact material	AgNi 0.15 gold-plated
Limit continuous current	6 A
Max. switching capacity	2000 VA, 50 W to 270 W
Recommended for loads	> 1 mA, 6 V dc
Max. output current	1 A
Recommended for loads	> 1 mA, 6 V dc
Alarm relay released at overload interruption undervoltage	$P_{\text{outputmax}} > 35\text{ W}$ $R_{\text{Load}} > 100\text{ k}\Omega$ $V_{\text{Supply}} < 18\text{ V dc}$

Ambient conditions

Temperature ranges	
Operation	- 10 °C to + 50 °C
Storage	- 25 °C to + 55 °C
Transport	- 25 °C to + 70 °C
Relative air humidity	Annual mean humidity $\leq 75\%$ $\leq 95\%$ for 30 days at 30 °C

Safety parameters

Insulation coordination acc. to DIN VDE 0110	Overvoltage category III Contamination degree 2
Safe isolation DIN 0106 Part 101 EN 61010-1	Double or reinforced insulation between control and load circuit Overvoltage category II Contamination degree 2 Max. operating voltage: 250 V ac

Insulation resistance between control section and output contact	4 kV _{eff} / 1 s
between error signal output and all other circuit parts	4 kV _{eff} / 1 s

Mechanical data

Enclosure	Add-on enclosure 22.5 mm x 78 mm x 110 mm without wire clamps see dimension drawing page 24
Mounting	Fitted on standard rail DIN EN 50022, 35 mm width
Protection class	Enclosure IP 40 Terminals IP 20
Shock protection acc. to DIN VDE 0106 Part 100	
Mechanical stability IEC 68-2-6	2 g / 0.15 mm / 10Hz to 150Hz
IEC 68-2-29	15 g / 6 ms
Maximum wire cross section	2 x 1.5 mm ² single core 1 x 2.5 mm ² single core 2 x 1.5 mm ² fine wire with connector sleeve to DIN 46228
Burning behaviour	self-extinguishing according to UL 94, IEC 707
Weight	150 g approx.

Order Details

Coupler KVF 11

Order number	31 - 95 - 1 _ _
Circuit of error signal contact	
None	11
2 x 100 k Ω	10
2 x 47 k Ω	12

Dimension Drawings

Type:
KRB 11
KRB 12

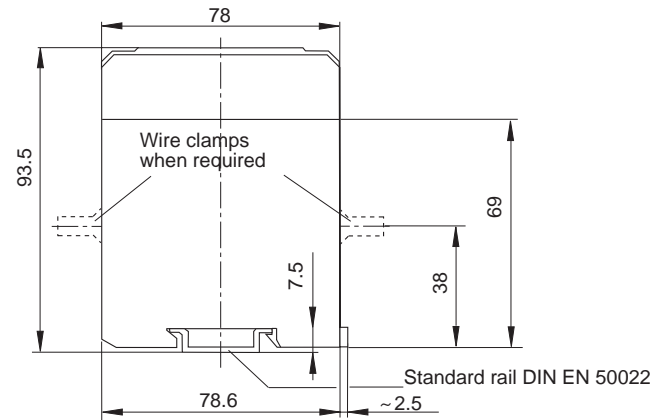
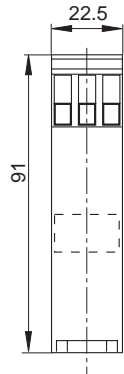

Type:
KRE 12
KRE 24
KRE 24A

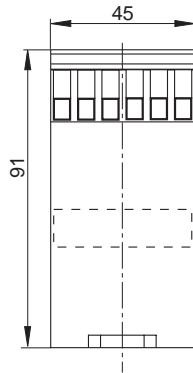

Type:
KRC 12
KRC 12A
KRD 22
KRD 22S
KRS 12
KRS 12K
KVF 11

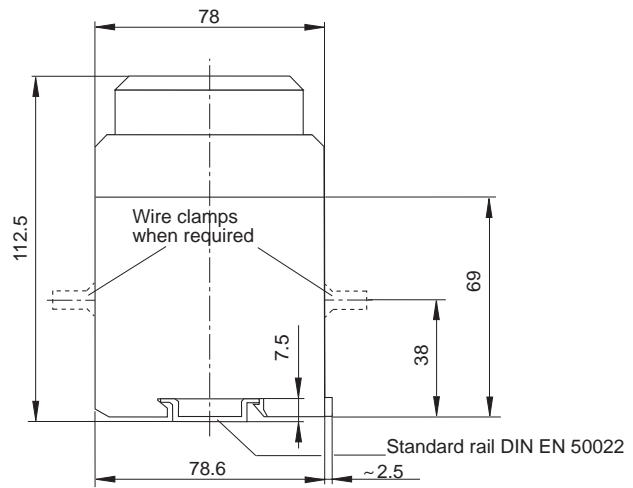
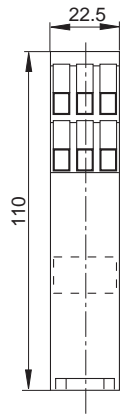

Type:
KRD 22U

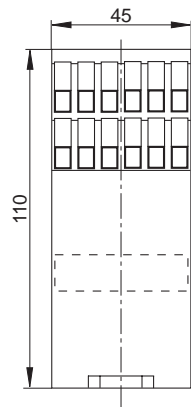

Representatives

Germany

Helmut Mauell GmbH

Am Rosenhügel 1 – 7

D-42553 Velbert

Tel.: +49 (0)20 53/1 30

Fax.: +49 (0)20 53/1 36 53

Internet: www.mauell.com

E-Mail: info@mauell.com

For an up-to-date list of all our representatives and branch offices, please visit our homepage: www.mauell.com

Representatives and Branch Offices

All Over The World:

Abu Dhabi U.A.E.	Iran
Argentina	Korea
Austria	Kuwait
Belgium	Netherlands
Brazil	Norway
Czech Republic	Poland
Denmark	Singapore
Finland	Spain
France	Sweden
Great Britain	Switzerland
Hungary	Turkey
	USA

mauell
*... your partner
in automation*

