

Auxiliary Relays



**HR 111,
HR 114, HR 115**

Contents:	Page
Application	4
Design and mode of operation	4
Special features	4
Technical data	4
Contact rating	5
Auxiliary relay HR 111	6
Circuit diagrams HR 111	6
Dimension drawings HR 111	6
Auxiliary relay HR 114	7
Circuit diagrams HR 114	7
Dimension drawings HR 114	7
Auxiliary relay HR 115	8
Circuit diagrams HR 115	8
Dimension drawings HR 115	10

Application

Auxiliary relays HR 111, HR 114 and HR 115 are suitable for use in virtually all electrical engineering sectors, particularly for control and monitoring systems. Because of their low power consumption, plug-in type design and high heavy-duty contact rating, these relays are preferably used for electrical isolation between control and operating circuits in systems of this type.

Design and mode of operation:

Auxiliary relays HR 111, HR 114 and HR 115 are designed as axial-armature relays. The armature operates all contacts simultaneously without the use of intermediate levers. In a de-energised state, the armature is kept in the rest position by the restoring force of the contact springs. By means of an armature restoring spring fitted at the works, a defined resetting ratio can be adjusted. The transparent housings protect the relays against dust and accidental contact. The plug-in boards are available with screw terminal for conductor cross-sections up to 4 mm² and solder terminal. The DC auxiliary relay types HR 111 and HR 114 can be ordered with a suppressor diode. Auxiliary relay HR 115 is available with pickup or dropout delay, with a pulse stretching circuit and as a ground fault monitoring relay. The delay time can be adjusted by maximum 0.5 seconds to suit the particular application by the provision of appropriate components.

The pulse stretching circuit serves to ensure reliable operation of the relay with very brief starting pulses. The circuit of the HR 115 is designed so that pulses of 25 ms result in reliable operation of the relay. As a ground fault monitoring relay, the HR 115 is provided with two windings and connected to the open delta winding of a displacement converter; it is designed for an operating voltage of 30 V AC. When the relay operates, the second winding is connected, so that the device can be reliably operated up to 100 V AC. This relay has been designed to give lasting service, even under harsh operating conditions.

Special features

Plug-in design, compact size, low power consumption, large number of contacts (also wiping contacts), high contact rating, large creepage distances, dust-tight transparent housing, long service life, highly reliable, independent of the mounting position.

Technical data

Energizing side

Type of current	DC or AC 50 Hz or 60 Hz
Rated voltage V_R	Up to 250 V DC or 250 V AC
Continuous overload capability	$1.2 \times V_R$
Operating voltage	$20.75 \times V_R$

Power input at rated voltage for

DC voltage	
HR 111	1.5 W to 2.0 W
HR 114	2.0 W to 3.5 W
HR 115	1.5 W to 2.0 W

AC voltage (open magnetic circuit)

HR 111	2.5 VA to 2.0 VA
HR 114	3.0 VA to 4.5 VA
HR 115	2.5 VA to 3.0 VA

AC voltage (closed magnetic circuit)

HR 111	2.0 VA to 2.5 VA
HR 114	2.5 VA to 3.5 VA
HR 115	2.0 VA to 2.5 VA

Operating time

HR 111	about 25 ms
HR 114	about 25 ms
HR 115	25 ms for pulse stretching relay, pulse delay relay according to order

Release time

HR 111	about 10 ms
HR 114	10 ms to 25 ms
HR 115	for impulse delay relay according to order

Resetting ratio for DC voltage

HR 111	1 : 3.3
HR 114	1 : 2
HR 115	for pulse delay relay according to order

for AC voltage

HR 111	1 : 1.5
HR 114	1 : 2
HR 115	for pulse delay relay according to order

Contact side:

Permissible switching voltage 220 V DC or 220 V AC
 Contact complement see circuit diagrams, page 6 to 9

Wiping time (for version with wiping contacts) about 60 ms

General data

Degree of protection IP 40, connections IP 00
 (DIN 40050)

Insulation group and nominal insulation voltage Group C, 250 V AC/DC
 (VDE 0110/11.72)

Test voltage 2 kV, 50 Hz (VDE 0435a/9.72)

Permissible ambient temperature range -5 °C to +40 °C

Weight
 HR 111 320 g
 HR 114 520 g
 HR 115 420 g

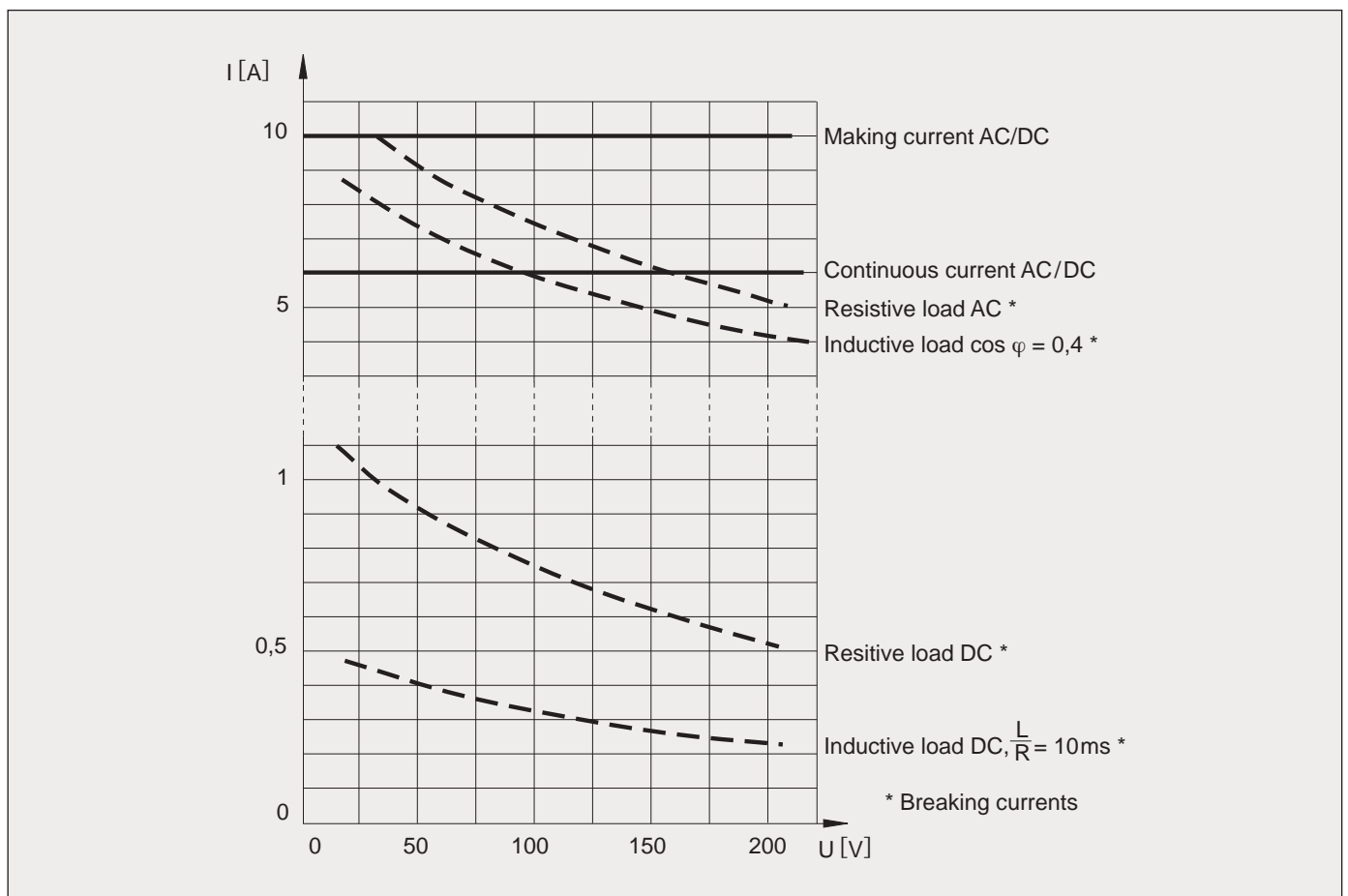
Contact rating at 10^5 switching operations

Auxiliary relays HR 111

Circuit diagrams HR 111

Circuit diagram 111-01

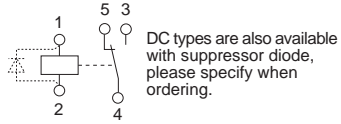

Circuit diagram 111-06

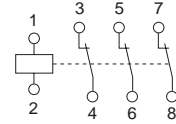

Circuit diagram 111-02

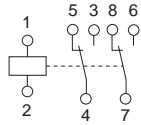

Circuit diagram 111-07

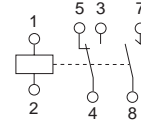

Circuit diagram 111-03

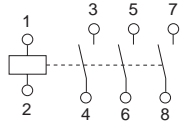

Circuit diagram 111-08

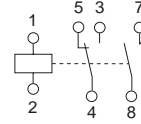

Circuit diagram 111-04

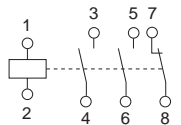

Circuit diagram 111-09

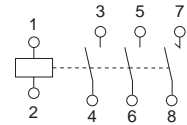

Circuit diagram 111-05

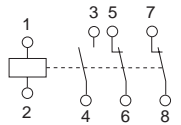

Circuit diagram 111-10

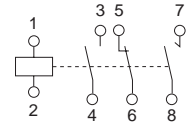

Dimension drawing HR 111 for panel-mounting

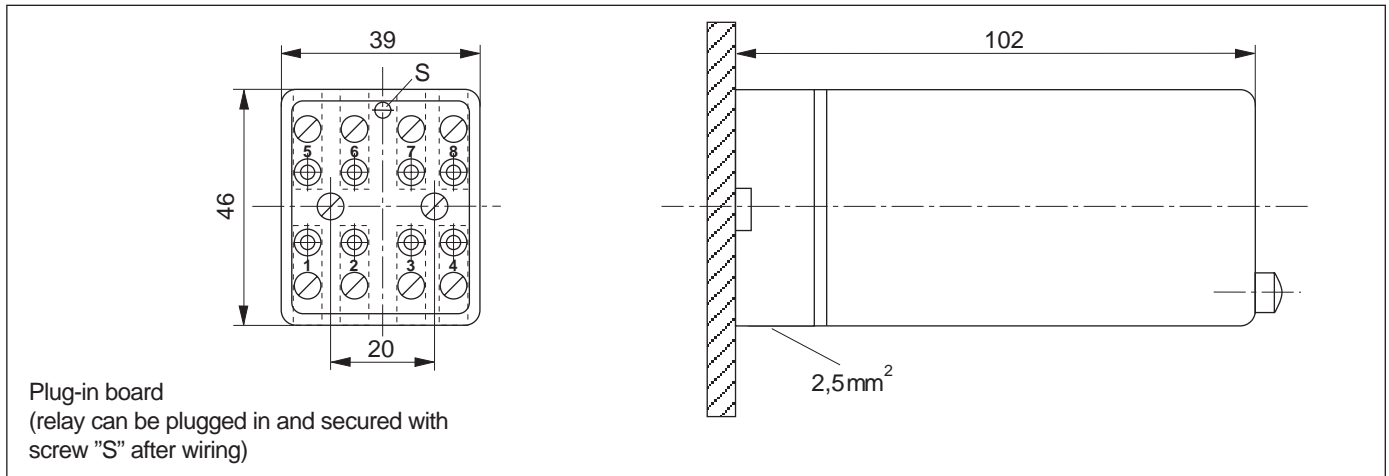

Dimension drawing HR 111 with top-hat rail fastening (35 mm)

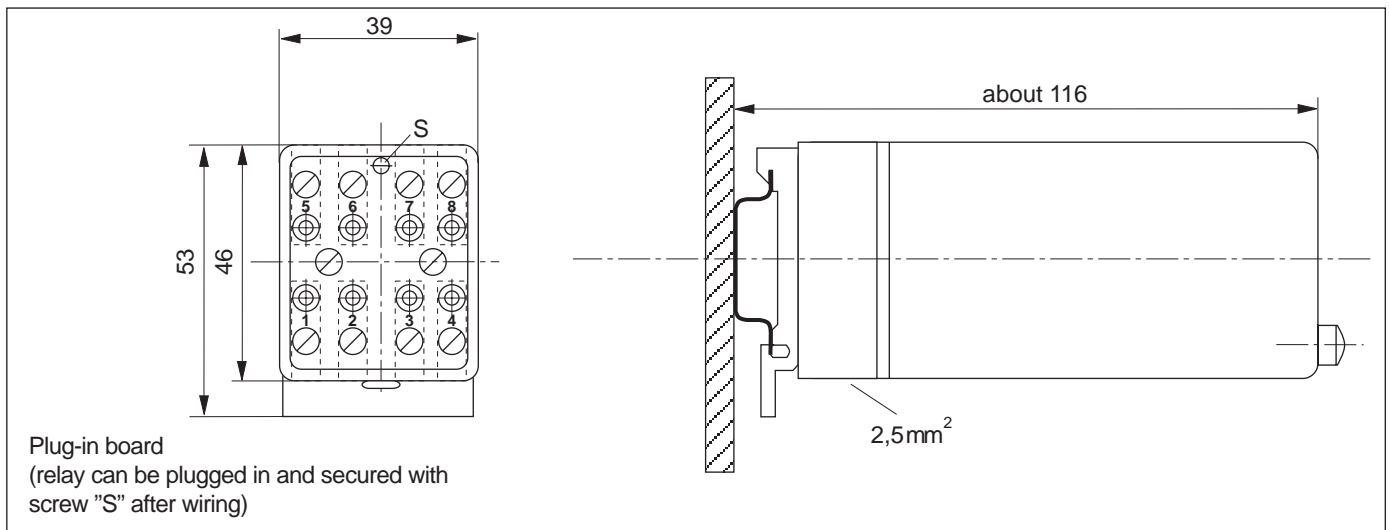

Circuit diagrams HR 114

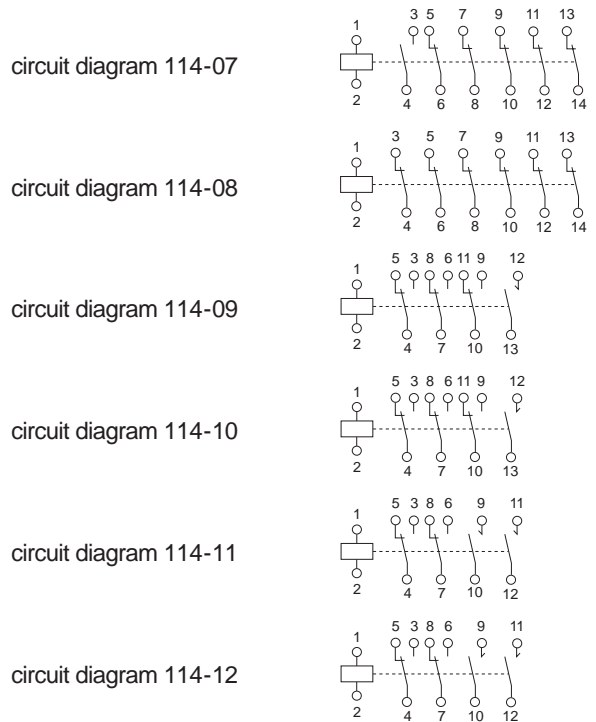
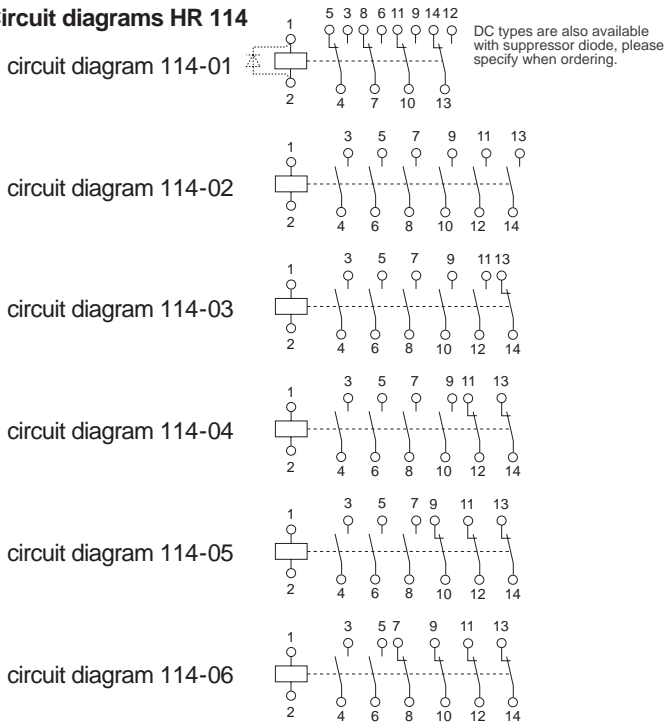

Dimension drawing HR 114 for panel-mounting

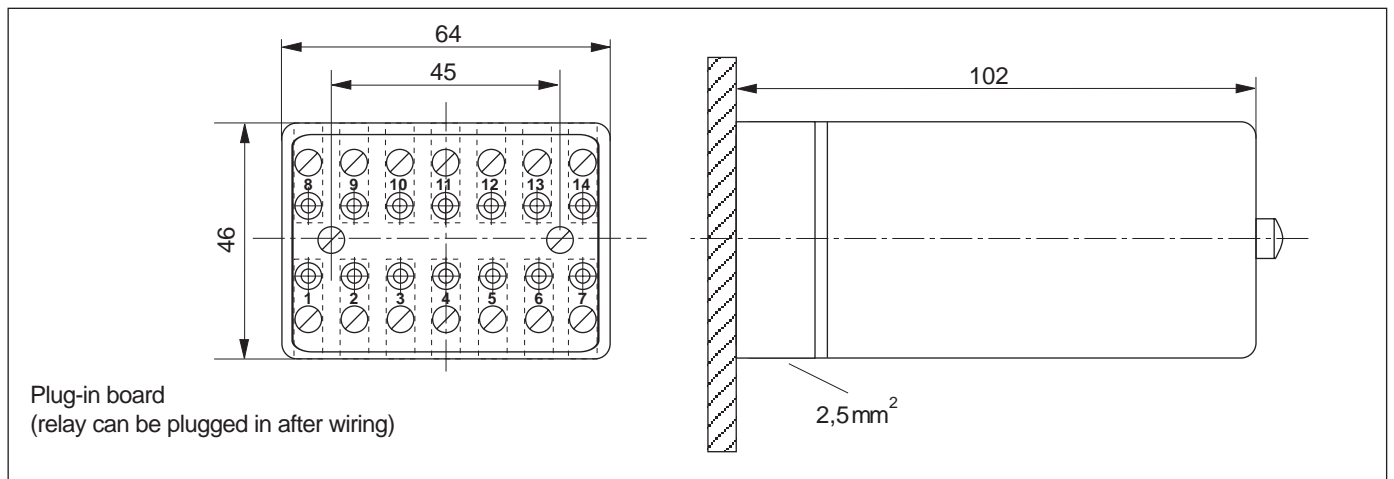

Dimension drawing HR 111 with top-hat rail fastening (35 mm)

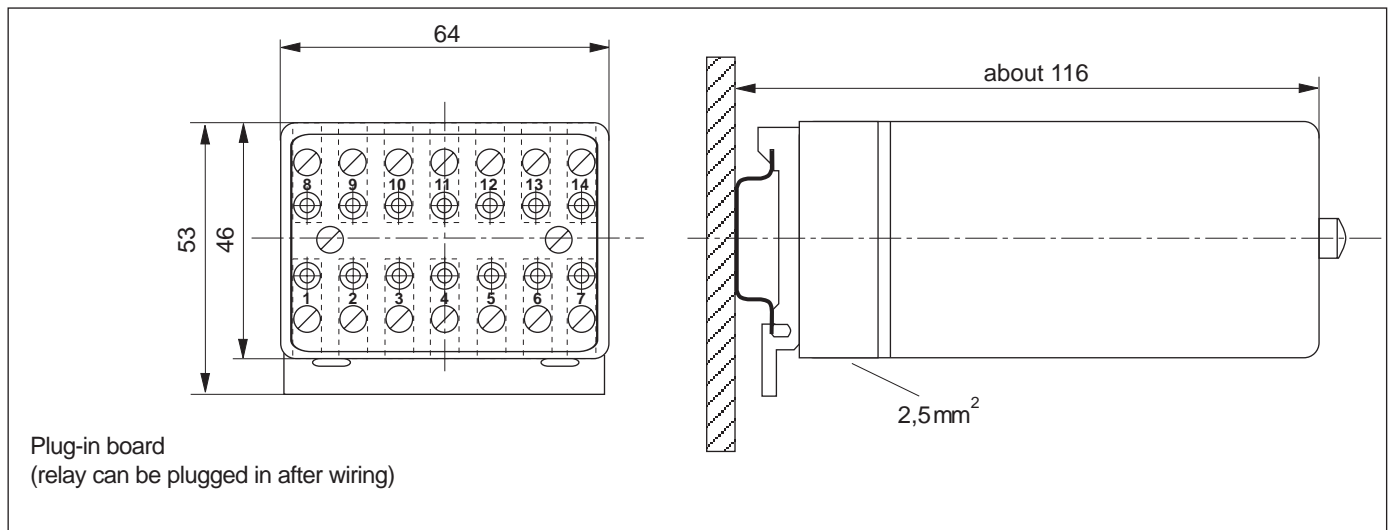

Auxiliary relays HR 115

Circuit diagram HR 115

HR 115 with pickup delay, preset delay time (maximum 0.5 s);
please specify delay time when ordering.

HR 115 with dropout delay, preset delay time (maximum 0.5 s);
please specify delay time when ordering.

circuit diagram 115-01 An

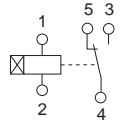

circuit diagram 115-01 Ab

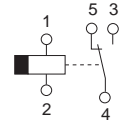

circuit diagram 115-02 An

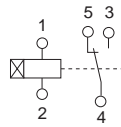

circuit diagram 115-02 Ab

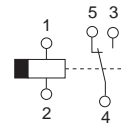

circuit diagram 115-03 An

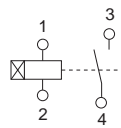

circuit diagram 115-03 Ab

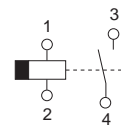

circuit diagram 115-04 An

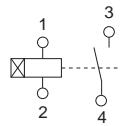

circuit diagram 115-04 Ab

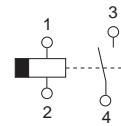

circuit diagram 115-05 An

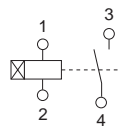

circuit diagram 115-05 Ab

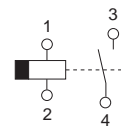

circuit diagram 115-06 An

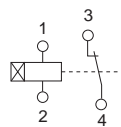

circuit diagram 115-06 Ab

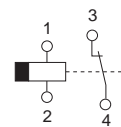

circuit diagram 115-07 An

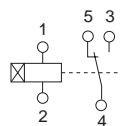

circuit diagram 115-07 Ab

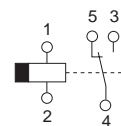

circuit diagram 115-08 An

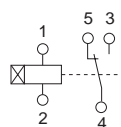

circuit diagram 115-08 Ab

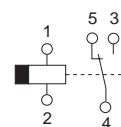

circuit diagram 115-09 An

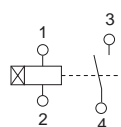

circuit diagram 115-09 Ab

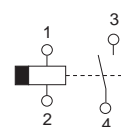

circuit diagram 115-10 An

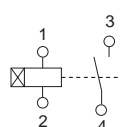

circuit diagram 115-10 Ab

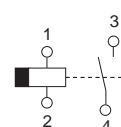

HR 115 for pulse stretching;
for 100% operating time

HR 115 for ground fault monitoring
(for connection to 30/100 V AC)

circuit diagram 115-01 Ip

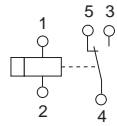

circuit diagram 115-02 E

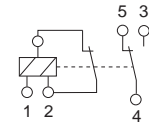

circuit diagram 115-02 Ip

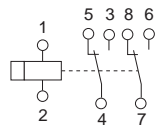

circuit diagram 115-04 E

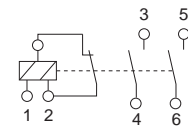

circuit diagram 115-03 Ip

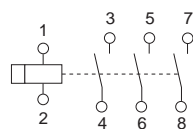

circuit diagram 115-05 E

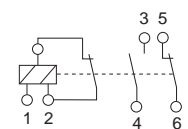

circuit diagram 115-04 Ip

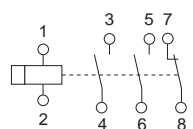

circuit diagram 115-06 E

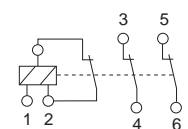

circuit diagram 115-05 Ip

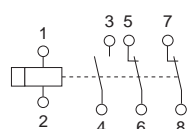

circuit diagram 115-07 E

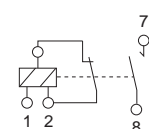

circuit diagram 115-06 Ip

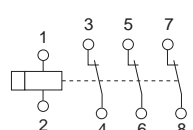

circuit diagram 115-08 E

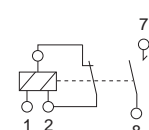

circuit diagram 115-07 Ip

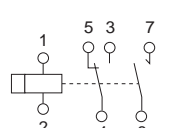

circuit diagram 115-10 E

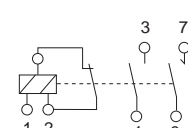

circuit diagram 115-08 Ip

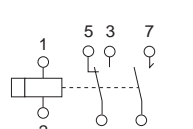

circuit diagram 115-09 Ip

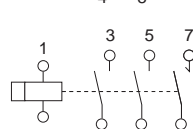

circuit diagram 115-10 Ip

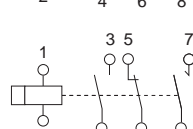

Dimension drawing HR 115 for panel-mounting

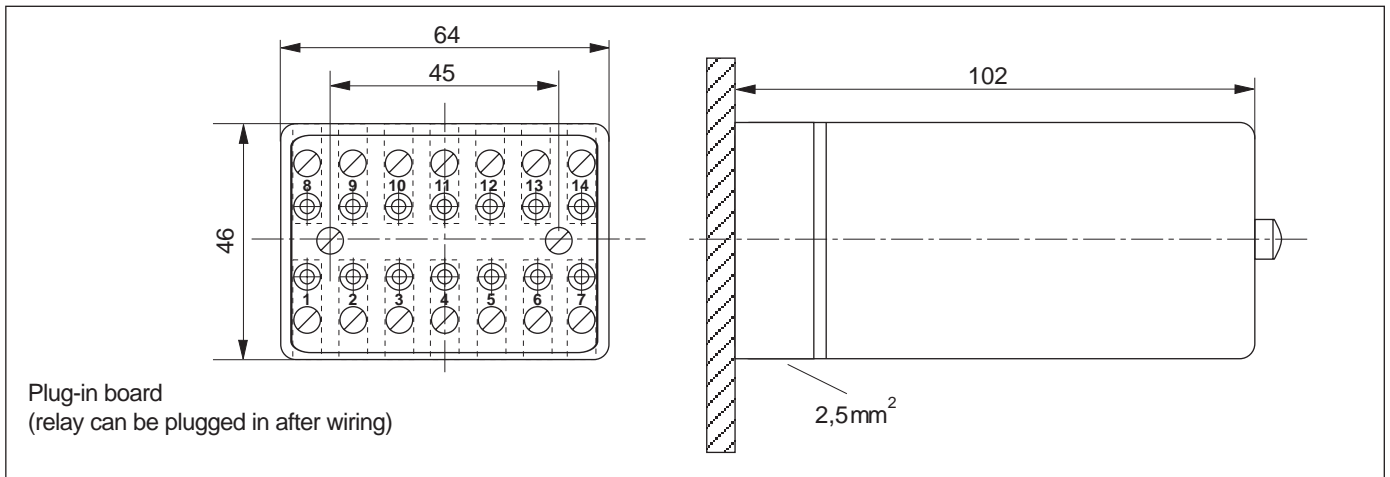

Dimension drawing HR 115 with top-hat rail fastening (35 mm)

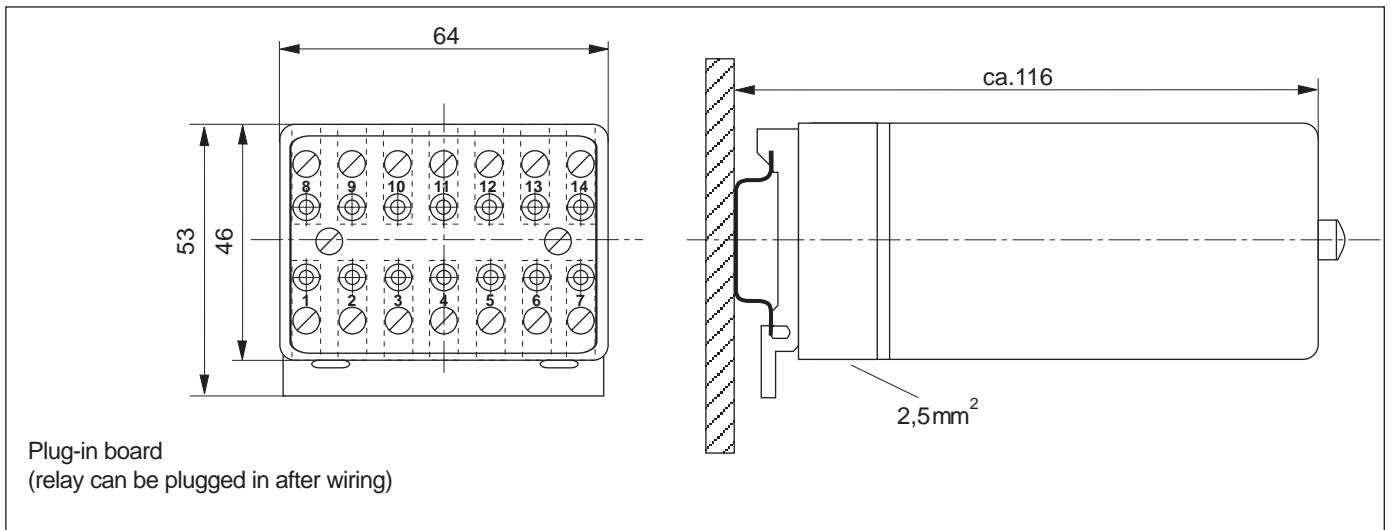

Representatives

Germany

Helmut Mauell GmbH

Am Rosenhügel 1–7

D-42553 Velbert

Tel.: +49 (0)20 53/1 30

Fax.: +49 (0)20 53/1 36 53

Internet: www.mauell.com

E-Mail: info@mauell.com

For an up-to-date list of all our representatives and branch offices, please visit our homepage: www.mauell.com

Representatives and Branch Offices

All Over The World:

Abu Dhabi U.A.E.

Argentina

Austria

Belgium

Brazil

Czech

Republic

Denmark

Finland

France

Great Britain

Hungary

Iran

Korea

Kuwait

Netherlands

Norway

Poland

Singapore

Spain

Sweden

Switzerland

Turkey

USA

mauell
*... your partner
in automation*

