

Electronic Alarm Indication Systems

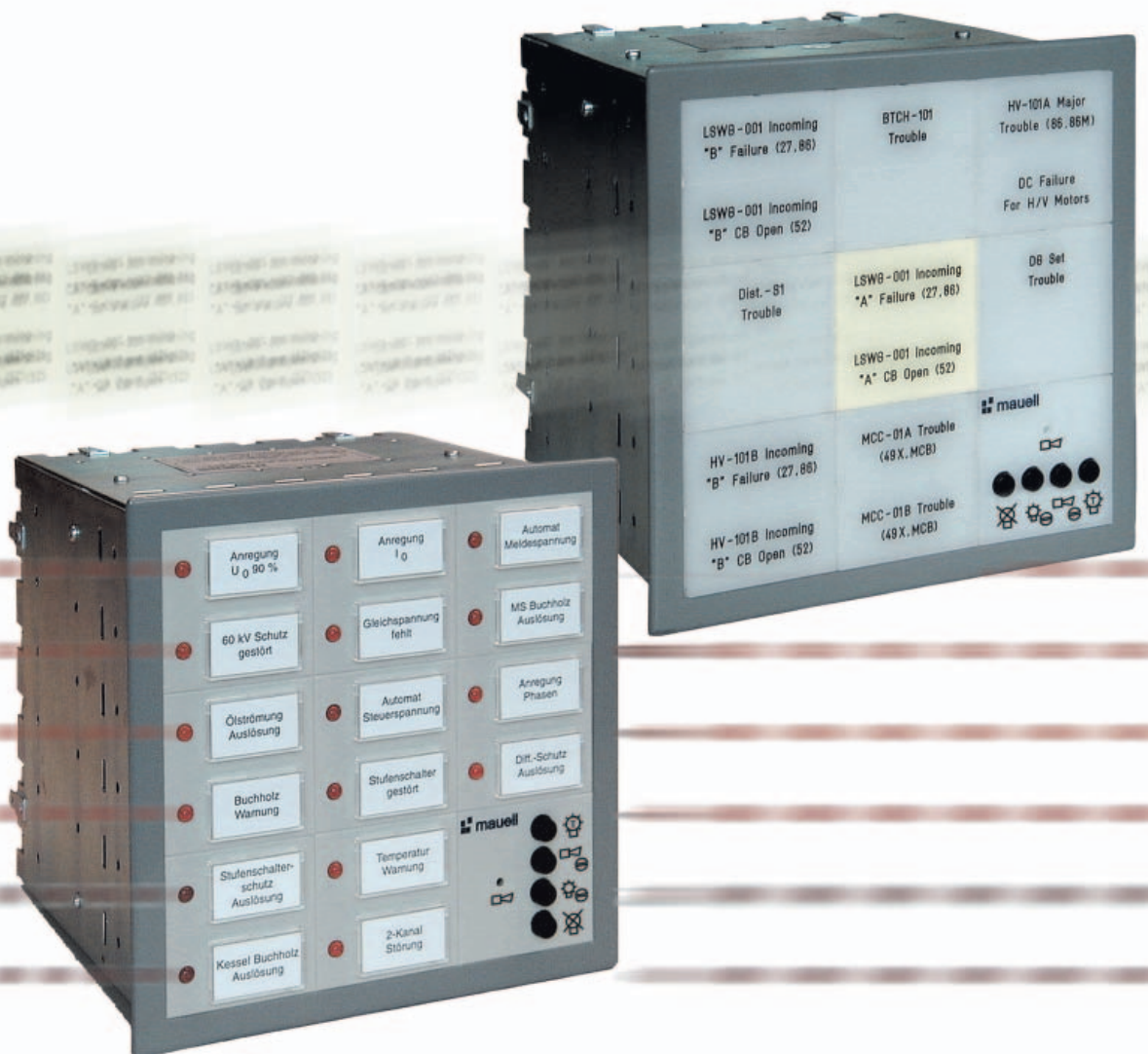

ME 3010

BTCH-101
Trouble

LSW0-001 Incoming
"A" Failure (27,86)

LSW0-001 Incoming
"A" CB Open (52)

MCC-01A Trouble
(49X, MCB)

MCC-01B Trouble
(49X, MCB)

Contents	Page
Functional Description	4
LED Display	4
Back-Light LED Display	4
Signalling Modes	4
Mechanical Design	4
Module Housing	5
Technical Characteristics	6
System Overview	
- Central Processing Module CM 02	6
- Message Signalling Module MF2 02	6
- Additional Contacts	7
- AAE: Automatic Acknowledgement at Module Switch-On	7
- Voltage Monitoring Module FVCC 01/DCF 01	7
- Protection Against Accidental Contact	7
- Power Supply Units and Transformers	7
- Switching Power Supply IPS 0.	7
- Switching Power Supply IPS 1. with Monitoring	7
- CE Certification	7
- Other Configurations	7
Dimensional Drawing for Systems with Back-Light LEDs	8
Dimensional Drawing for Systems with LEDs	10
Voltage Supply for Systems with Back-Light LEDs	12
Voltage Supply for Systems with LEDs	13
Connecting the Signalling Voltage to Systems with Back-Light LEDs	14
Connecting the Signalling Voltage to Systems with LEDs	14
External Pushbuttons and External Horn	15
Voltage Monitoring Module FVCC/DCF 01	15
Signalling Sequences Acc. to ISA	16
Maintenance	17
Status of Delivery	17
High-Voltage Test	17
Order Check List	17
Description of the CM 02 CPU Module	18
- Selecting the ISA Signalling Sequence and Other Settings	19
Description of the MF2 02 Message Signalling Module	20
- Setting the Message Processing Modes	21
Description of the Insertable Switching Power Supply IPS 0.	22
Description of the Insertable Switching Power Supply IPS 1. with Monitoring	23
Description of the Insertable RRO Auxiliary Relays	24
Description of the External Relay Adaptors	24



ME 3010 Alarm indication system with LED display

Functional Description

The distributed ME 3010 systems indicate process alarms and events, and pass this information on to other equipment for further processing. The alarms and events (from now on referred to as “messages”) are indicated by LEDs and text labels so that the operator is always informed about the nature of the message and the number of messages currently pending.

Depending on the type of ME 3010 system used, the messages are indicated by LEDs or by a powerful back-light display. One message signalling module displays 2 messages and occupies one slot in the ME 3010 system housing. One ME 3010 alarm indication system can display up to 238 messages.

LED Display

The red, green and yellow LEDs protrude from the faceplate of the ME3010 module so that the operator can easily recognize whether they are lit or not, even standing sideways of the panel. The message text is inscribed on a label which is inserted in a transparent plastic pocket adjacent to the LED.

Back-Light LED Display

A frontplate made of transparent white acrylic glass is lit from the back by a group of surface LEDs which light up in red or yellow-white colour. The message texts can either be engraved directly in the module front or printed on a transparency using a laser printer, and then glued onto the module.

Signalling Modes

Different ISA signalling sequences are available. For each message you can decide whether the signal is to be generated by working current (N/O) or zero current (N/C), and whether the incoming message is to be displayed by a static light or a flashing light. Incoming messages can also trigger an acoustic signal. If you choose message processing with double flashing light, then outgoing messages, too, are indicated by a flashing light. You may set the system to respond to first-up signals or to new value signals.

Mechanical Design

The rugged and resistant mechanical construction makes the ME 3010 alarm indication systems particularly suitable for use in industrial and power station environments. As each module handles both the processing and the display of process signals, an alarm system composed of several ME 3010 units is a compact and economical solution for the indication of 2 to 238 messages. It can be expanded as required, module by module. The ME 3010 system comprises one CPU module, the number of message signalling modules required, a housing and a power supply, if voltages higher than 60 V d.c. are required. Pushbuttons on the faceplate of the CPU unit activate the global functions, such as “Horn acknowledge, LED acknowledge, Function test, LED test and Delete (for the signalling sequences)”. These functions are also connected to terminals so that they can be triggered by external pushbuttons.

To make the signal inputs immune to noise voltages which could be caused, for instance, by unprofessional input cabling, all signal inputs are designed to respond with a delay. A high degree of noise immunity has been achieved by inserting a varistor protection in the input circuit, electrically isolating the inputs from the internal signal circuits by means of optocouplers, and by using CMOS circuit components.

Relay adaptors, or so-called front relays, that can be connected to the rear terminals allow you to provide message transfer contacts and generate group messages, or groups of group messages.

The ME 3010 series offers modules for supply voltages of 24 V, 48 V, 60 V d.c. and signalling voltages of 12 V, 24 V, 48 V, 60 V, 110 V/125 V d.c., and 110/127 V a.c.

Housing

The housing is quadratic or rectangular, depending on the number of signals to be processed. The plug-in modules are inserted in the housing from the front.

The rear of the housing contains a printed circuit board and provides access for wiring. The p.c.b. carries all internal wiring and connection terminals. All modules in the housing are connected with this circuit board through plug connectors.

Four signal input terminals are provided for each message signalling module. The terminals for the connection of an external horn and external pushbuttons are also located on the rear circuit board.

Technical Characteristics





Supply voltage	24 V, 48 V or 60 V d.c. ($\pm 20\%$)	
For other voltages and for processing of up to 60 messages, the insertable IPS power supply modules can be used.		
Input voltages	90 to 264 V ac, 100 to 275 V d.c.	
Ripple content	Lower than 5%	
Systems processing more than 60 messages receive their supply voltage from an external power supply unit.		
Signalling voltages		
DC	12 V, 24 V, 48 V, 60 V, 110 V/125 V, $\pm 20\%$	
AC	110/127 V; $\pm 20\%$	
Signal definition	"0" signal	"1" signal
for 24 V	0 V to +5 V	+15 V to +30 V
for 48 V	0 V to +9 V	+30 V to +58 V
for 60 V	0 V to +14 V	+45 V to +72 V
Delays	DC	AC
Response to working current (N/O)	5 ms	100 ms
Response to zero current (N/C)	20 ms	140 ms
The signal inputs are electrically isolated from each other and protected against noise voltages by means of varistors.		
Admissible working temperature	0 °C to 50 °C	
Protection class		
Front	IP41	
Housing	IP40	



ME 3010 alarm indication system with back-light LED display

System Overview

Central Processor Unit CM 02

- One CPU module for each ME 3010 signalling system
- Integrated pushbuttons
 -  LED test or function test
 -  Horn acknowledgement
 -  LED acknowledgement
 -  Delete
- Terminals for external pushbuttons
- Integrated horn
 - Sound pressure 90 dB at distances of 10 cm
 - Sound frequency 4 kHz
 - Sustained or clocked signal
- Frequency of the flashing generator
 - fast: 1.2 Hz approx.
 - slow: 0.4 Hz approx.
- Signalling sequence
 - ISA, selectable by means of coding jumpers
- Automatic horn acknowledgement after 5 seconds approx.
- Relay contact for external horn
 - floating N/O contact 500 mA / 75 V
- Special functions
 - The use of two central processing units makes it possible to generate two different acoustic signals, one for critical messages and one for messages of lesser importance, or to generate a contact for group messages (central group, single signalling).
- Sleep mode

Only applies to signalling systems with external power supply. With this mode, the entire visual and acoustic message indication (LED display and horn) is deactivated.



- Mode of input energization Working current (N/O) or zero current (N/C) energization, selectable separately for every input by means of SMD jumpers
- Option: status message without alarm indication (selectable)

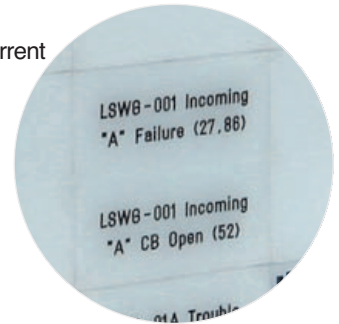

LED Display

- Message indicating area: light-grey polycarbonate front module (RAL 7032)
- Paper labels that are inserted in a transparent plastic pocket on the module front plate
- LED colours: red, green, yellow
- Current consumption: 35 mA for each message
- Signal delay: 5 ms to 20 ms approx. for d.c. supply, and 100 ms to 140 ms approx. for ac supply
- Mode of input energization Working current (N/O) or zero current (N/C) energization, selectable separately for every input by means of SMD jumpers
- Option: status message without alarm indication (selectable)

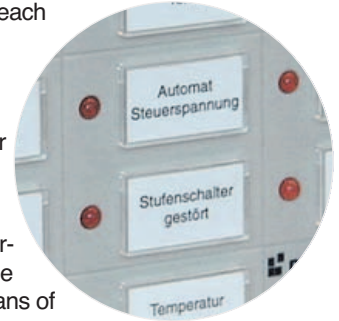

Message Signalling Module MF2 02 – for 2 Messages

Back-Light LED Display

- Message indicating area: white front module made of semi-transparent acrylic glass
- Labelling: engravings of max. 4 lines for each message, 19 characters per line, 3 mm height
- Laser print labels are produced using the ASK 1 Label Printing Kit, which contains self-adhesive labels that can be printed as required and then stuck on the message indicating surface of the MF2 02 front panel.
- Colour of the supralight surface LED groups: red or yellow-white
- Current consumption: 35 mA for each message
- Signal delay 5 ms to 20 ms approx. for d.c. supply, and 100 ms to 140 ms approx. for ac supply

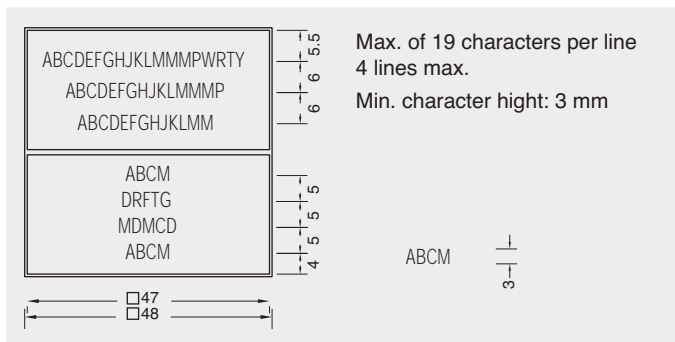

Faceplate of the back-light LED display module

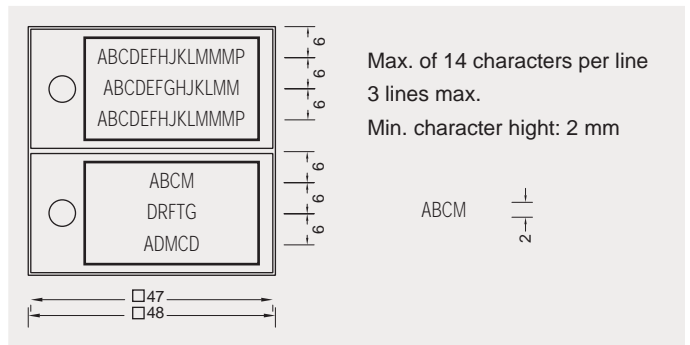

Faceplate of the LED display module

Additional Contacts

- RRO are integrated relays with one floating N/O contact for each message. They are an optional feature and are integrated in the signalling module on request. They provide 4 additional terminals on the rear plate.
- RV2 relays are separate relay adaptors that can be connected to the terminals on the rear module plate. They repeat contact signals and make these available for further processing in the form of floating contacts:
 - RV2 01, 1 N/O contact for each message
 - RV2 21, 2 N/O contacts for each message
 - RV2 13, 1 change-over contact for each message
 - RV2 14, 1 monostable N/O contact for each message, pulse duration: 80 ms to 150 ms approx.
 - RV2 02, electrical isolation for each message
- Contact characteristics
 - Maximum voltage: 150 V d.c. (ohmic)
 - Maximum current: 500 mA (ohmic)

AAE: Automatic Acknowledgement at Module Switch-On

- The AEE function is integrated in the rear printed circuit board MB 01. It automatically acknowledges all pending messages each time the module is switched on (option).

Voltage Monitoring Modules FVCC 01/DCF 01

- The module combination FVCC 01/DCF 01 can be ordered as an option. It occupies one slot in the ME 3010 system housing. The FVCC 01 unit is supplied by an a.c. auxiliary voltage and monitors the presence of the d.c. system supply voltage. Voltage failure is indicated visually, and by a floating change-over contact.
- Voltage 127 V a.c.
- 1 floating change-over contact
- Reset button on faceplate
- LED or by back-light LED indication on faceplate.
- The DCF 01 module monitors the d.c. supply voltage.
- Voltage monitoring of d.c. voltages: 24 V, 48 V, 60 V, and 110V/125 V

MRP: Protection against Accidental Contact

- The MRP function protects against accidental contact with the rear MB 01 circuit board of the system. However, this protection has no effect if RV2 relay adaptors are used.

Power Supply and Transformer Units

- The ME 3010 signalling system is designed for voltages of 24 V, 48 V and 60 V. IPS supply modules and external transformer units with electrical isolation are available for use with higher voltages. Information on request.

Insertable IPS 0. Switching Power Supply

- The numbers following the dot in the IPS designation indicate the type of the supply unit.
- The IPS unit is an option and can be inserted in the ME 3010 system. It occupies the same space as one message signalling module.
- Voltage supply for up to 32 or 60 messages
- Input voltage from 90 V to 264 V a.c. or from 100V to 275 V d.c.
- Output voltage: 24 V d.c.

• Please note:

- ME 3010 system housings with integrated IPS switching power supply must have a minimum size: (V= vertical, H=horizontal)
- Signalling system with back-light LED display: 4 V x ___ H
The supply module occupies the slot above the CPU module (see dimensional drawing on page 8).
 - Signalling system with LED display: ___ V x 2 H.
The supply module occupies the slot next to the CPU module (see dimensional drawing on page 10).

• IPS 1. Switching Power Supply with Monitoring

- The numbers following the dot in the IPS designation indicate the type of the supply unit.
- The IPS unit is an option and can be inserted in the ME 3010 system. It occupies the same space as one message signalling module.
- Voltage supply for up to 32 or 60 messages
- Input voltage from 90 V to 264 V a.c. and/or from 100 V to 275 V d.c.
- Output voltage: 24 V d.c.
- 2 floating N/C contacts for fault indication:
 - DC supply failure
 - AC supply failure

• Please note:

- ME 3010 system housings with integrated IPS switching power supply must have a minimum size: (V= vertical, H=horizontal)
- Signalling system with back light LED display: 4 V x ___ H
The supply module occupies the slot above the CPU module (see dimensional drawing on page 8).
 - Signalling system with LED display: ___ V x 2 H.
The supply module occupies the slot next to the CPU module (see dimensional drawing on page 10).

• CE Certification

- The ME 3010 products are designed for use in industrial environments and comply with the European 89/336/EWG Regulations (guidelines of the council for homogeneous regulations of the EC member countries in the field of electromagnetic compatibility).

Other ME 3010 Configurations (On Request)

- Sleep Mode: available for systems with external power supply
 - Deactivates the entire visual message indication with LEDs
 - Sleep mode switch: on front plate
- Signalling modules for status indication (without additional signalling)
- Yellow LEDs for status indication
- Signalling system with remote signalling module
- Automatic acknowledgement of LEDs
- Combination of LED acknowledge and horn acknowledge)
- RUN indication
- Signalling of simple remote operation
- 2 horns (2 CM 02 CPU modules) with or without switch-off

Please request information on the above special functions, or any other requirements you may have, from Mauell GmbH.

Dimensional Drawing for ME 3010 Systems with Back-Light LED Display

The system's dimensions and panel cutout requirements are shown in the diagram below.

When selecting the size of the housing, please bear in mind that every ME 3010 system needs at least one CPU module, one or more MF2 message signalling modules and additional modules for voltage supplies and monitoring, if applicable. The shaded sizes

are too small if you want to use the IPS-type integrated switching power supply units.

Always use the special tool (see accessories list) to remove an ME 3010 front module.

			Panel cutout.											
			Housing											
68	58	57	1	2	3	4	5	6	7	8	9	10	11	12
68	58	57	1	2	3	4	5	6	7	8	9	10	11	12
116	106	105	3	4										
164	154	153	5	6										
212	202	201	7	8										
260	250	249	9	10										
308	298	297	11	12										
356	346	345	13	14										
404	394	393	15	16										
452	442	441	17	18										
500	490	489	19	20										

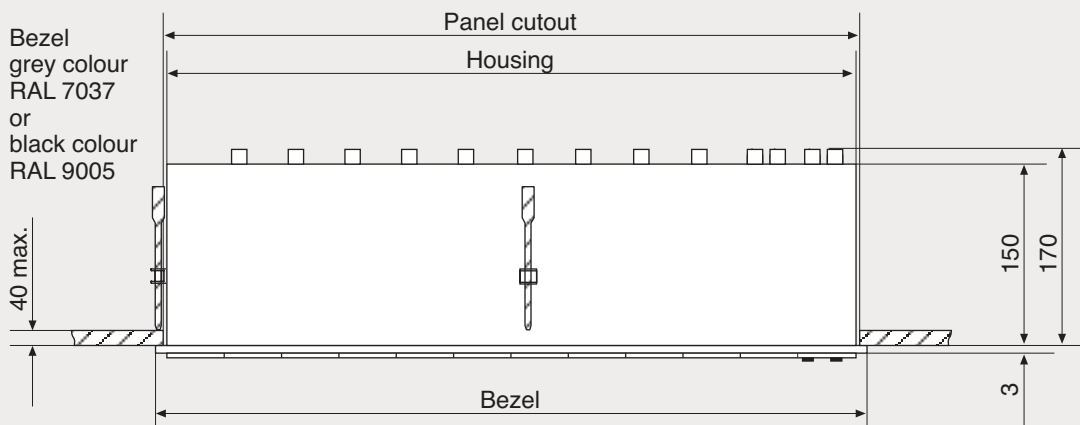

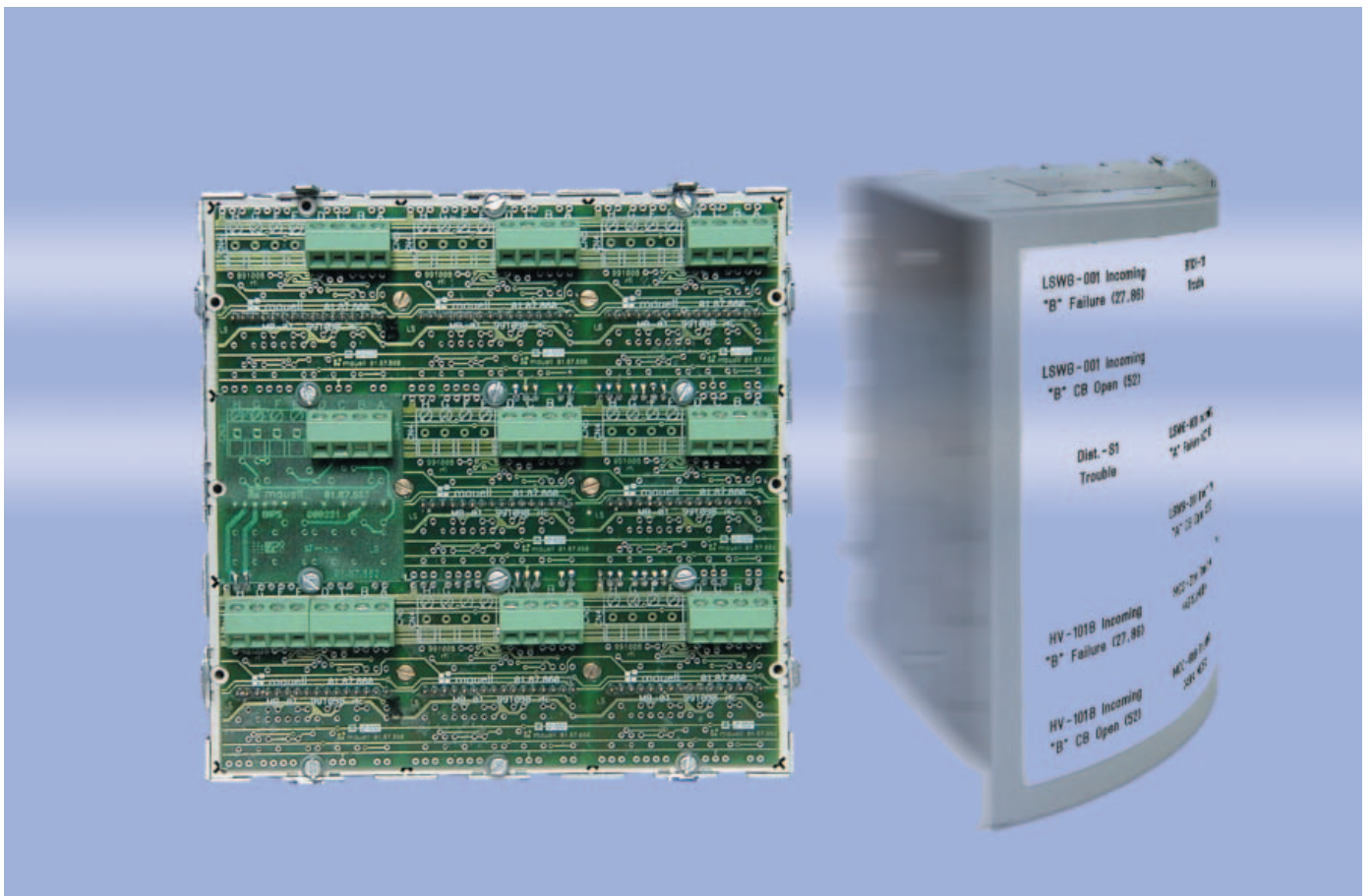

ME 3010 alarm indication system with back-light LED display

Dimensional Drawing for the ME 3010 Systems with LED Display

The system's dimensions and panel cutout requirements are shown in the diagram below.

When selecting the size of the housing, please bear in mind that every ME 3010 system needs at least one CPU module, one or more MF2 signalling modules and additional modules for voltage supplies and monitoring, if applicable. The shaded sizes are too

small if you want to use the IPS-type integrated switching power supply units.

Always use the special tool available (see accessories list) to remove an ME 3010 front module.

			Panel cutout									
			Housing									
			1	2	3	4	5	6	7	8	9	10
68	58	57	1	2	3	4	5	6	7	8	9	10
116	106	105	3	4	5	6	7	8	9	10	11	12
164	154	153	5	6	7	8	9	10	11	12	13	14
212	202	201	7	8	9	10	11	12	13	14	15	16
260	250	249	9	10	11	12	13	14	15	16	17	18
308	298	297	11	12	13	14	15	16	17	18	19	20
356	346	345	13	14	15	16	17	18	19	20	21	22
404	394	393	15	16	17	18	19	20	21	22	23	24
452	442	441	17	18	19	20	21	22	23	24		
500	490	489	19	20	21	22	23	24				
548	538	537	21	22	23	24						
596	586	585	23	24								

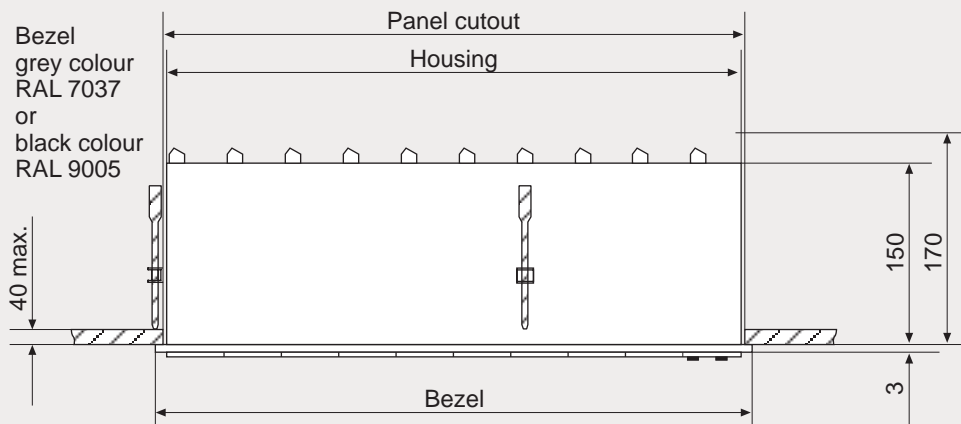

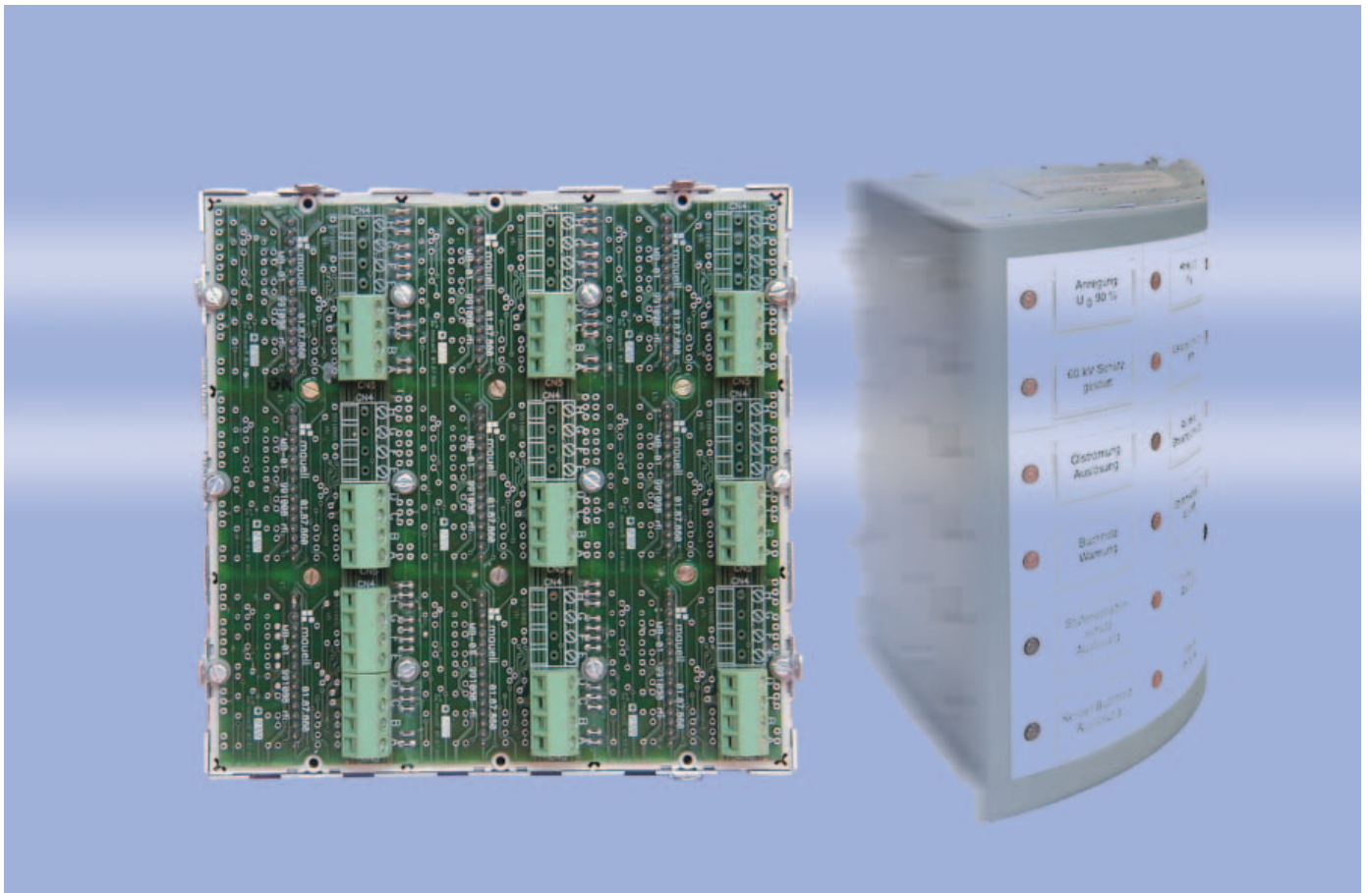

ME 3010 alarm indication system with LED display

Power Supply for the ME 3010 Systems with Back-Light LED Display

Rear view of the housing, left-hand side

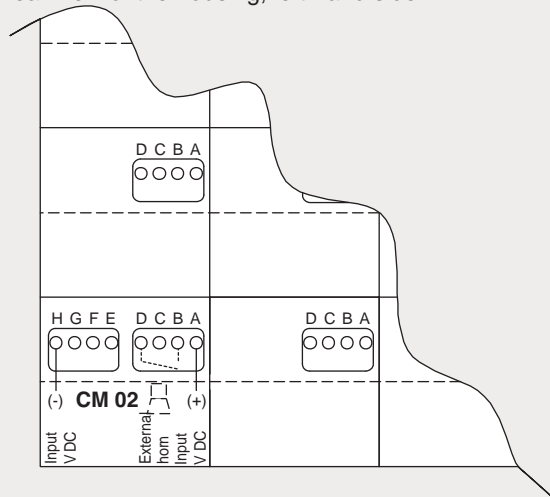

Systems with External Supply Voltage

- Supply voltage input to rear terminals (24, 48 or 60 V d.c.)
 - Terminal "A" of CPU module CM 02 to positive potential (+)
 - Terminal "H" of CPU module CM 02 to negative potential (-)

Connection of an external power supply

Rear view of the housing, left-hand side

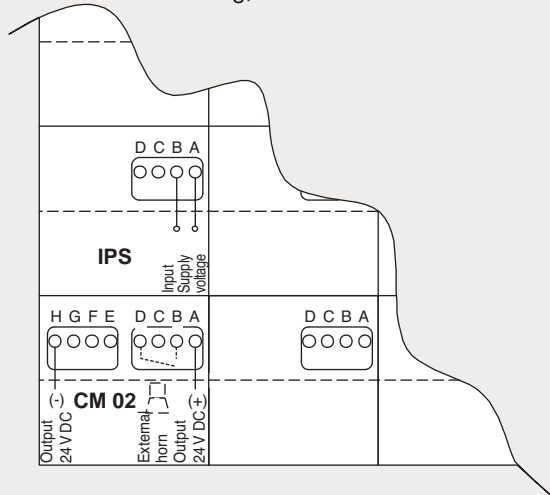

Systems with Integrated IPS 0. Power Supply

- Connection of power supply unit
 - Terminals "A" and "B" of the IPS module
- Connect the 24 V d.c. output (signalling voltage) to
 - terminal "A" of CPU module CM 02, positive potential (+)

Connection of an integrated power supply

Rear view of the housing, left-hand side

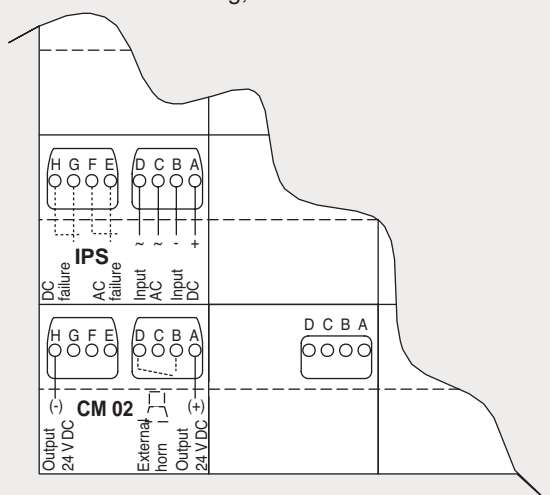

Systems with Integrated IPS 1. Power Supply and Monitoring

- Input of the IPS power supply unit at terminals
 - "A" : d.c. positive (+), "B" : d.c. negative potential (-)
 - "C" and "D" : ac ~
- Monitoring at terminals
 - AC voltage monitoring
 - "E" and "F" : floating N/C contact "AC failure"
 - DC voltage monitoring
 - "G" and "H" : floating N/C contact "DC failure"
- 24 V dc output (signalling voltage) at terminals
 - "A" of CPU module CM 02, positive potential (+)
 - "H" of CPU module CM 02, negative potential (-)

Connection of an integrated power supply with voltage monitoring

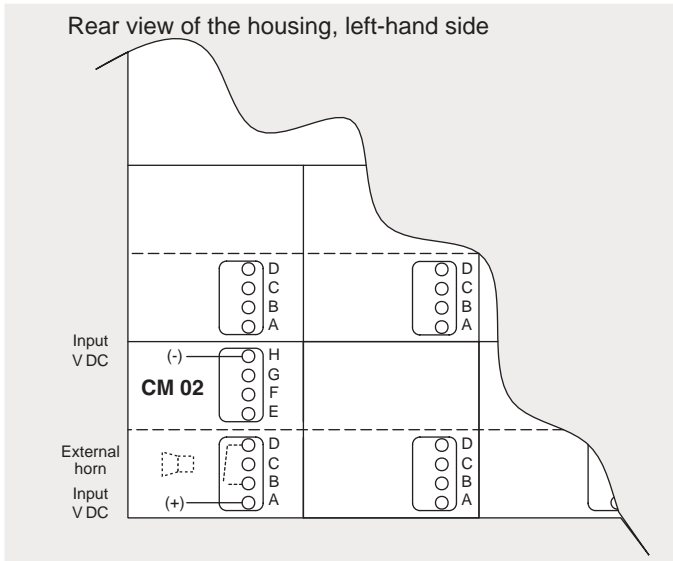

Systems with External Supply Voltage

- Supply voltage input to rear terminals (24, 48 or 60 V d.c.)
 - Terminal "A" of CPU module CM 02 to positive potential (+)
 - Terminal "H" of CPU module CM 02 to negative potential (-)

Connection of an external power supply

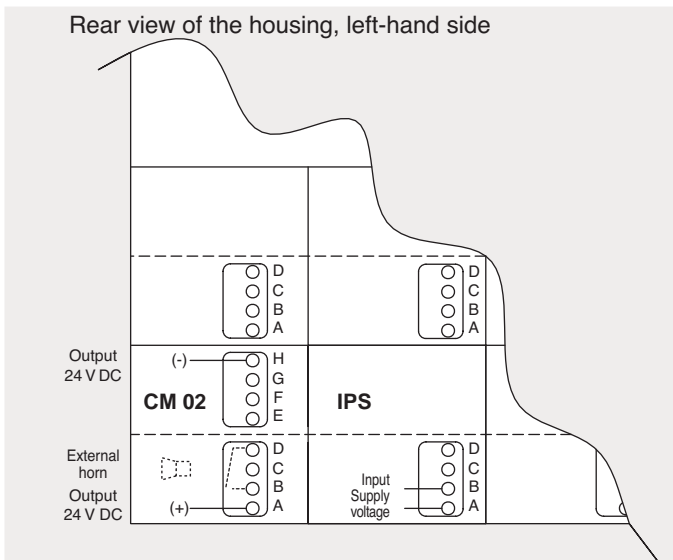

Systems with Integrated IPS 0. Power Supply

- Connection of power supply unit
 - Terminals "A" and "B" of the IPS module
- Connect the 24 V d.c. output (signalling voltage) to
 - terminal "A" of CPU module CM 02, positive potential (+)

Connection of an integrated power supply

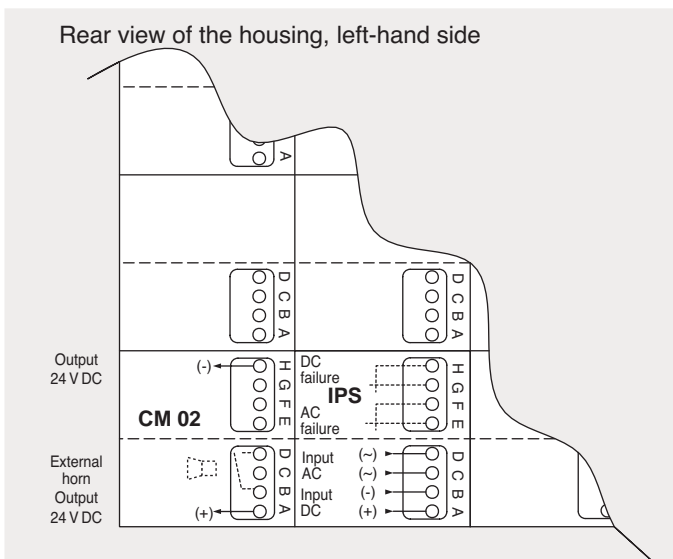

Systems with Integrated IPS 1. Power Supply and Monitoring

- Input of the IPS power supply unit at terminals
 - "A" : d.c. positive (+), "B" : d.c. negative (-)
 - "C" and "D" : ac ~
- Monitoring at terminals
 - AC voltage monitoring
 - "E" and "F" : floating N/C contact "AC failure"
 - DC voltage monitoring
 - "G" and "H" : floating N/C contact "DC failure"
- 24 V d.c. output (signalling voltage) at terminals
 - "A" of CPU module CM 02, positive potential (+)
 - "H" of CPU module CM 02, negative potential (-)

Connection of an internal power supply with voltage monitoring

Connecting the Signalling Voltage

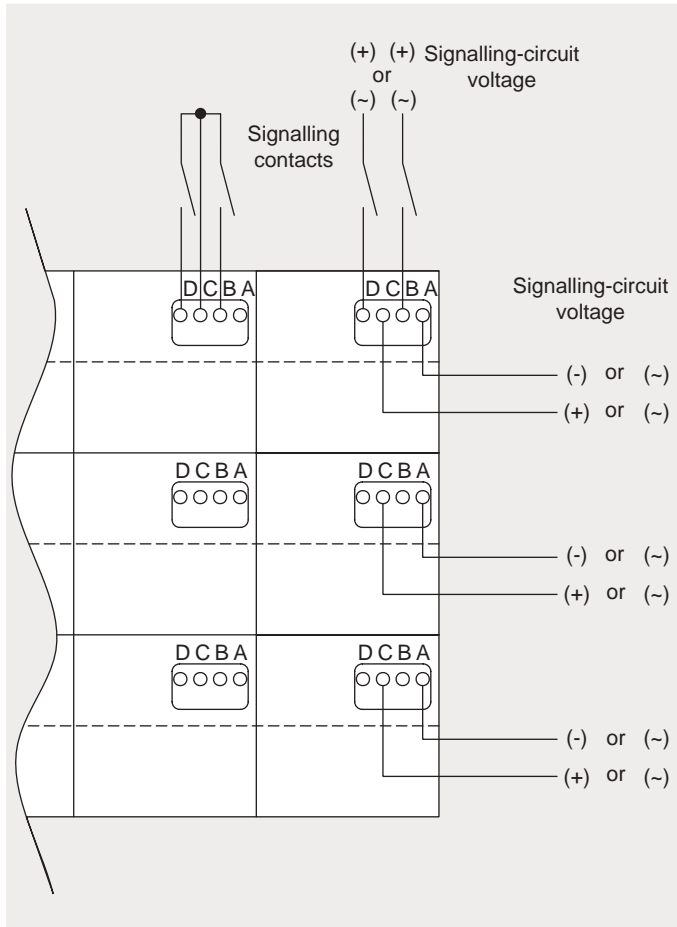

Terminals on the rear panel of the ME 3010 system

Connecting the Signalling Voltage in Systems with Back-Light LED Display

All terminal blocks of the right-hand column (rear panel) must be connected as follows:

- Terminals "A": to negative potential (-) of signalling voltage
- Terminals "C": to positive potential (+) of signalling voltage

This connects the signalling voltage to all message signalling modules of one line.

The positive potential of the signalling voltage is also available at the other "C" terminals.

• Message inputs at terminals:

- Terminals "B" – for the lower message field
- Terminals "D" – for the upper message field

• Terminals "C" – positive potential (+) of the signalling voltage for the supply of floating signalling contacts.

Connecting the Signalling Voltage in Systems with LED Display

All terminal blocks of the second upper line (rear panel) must be connected as follows:

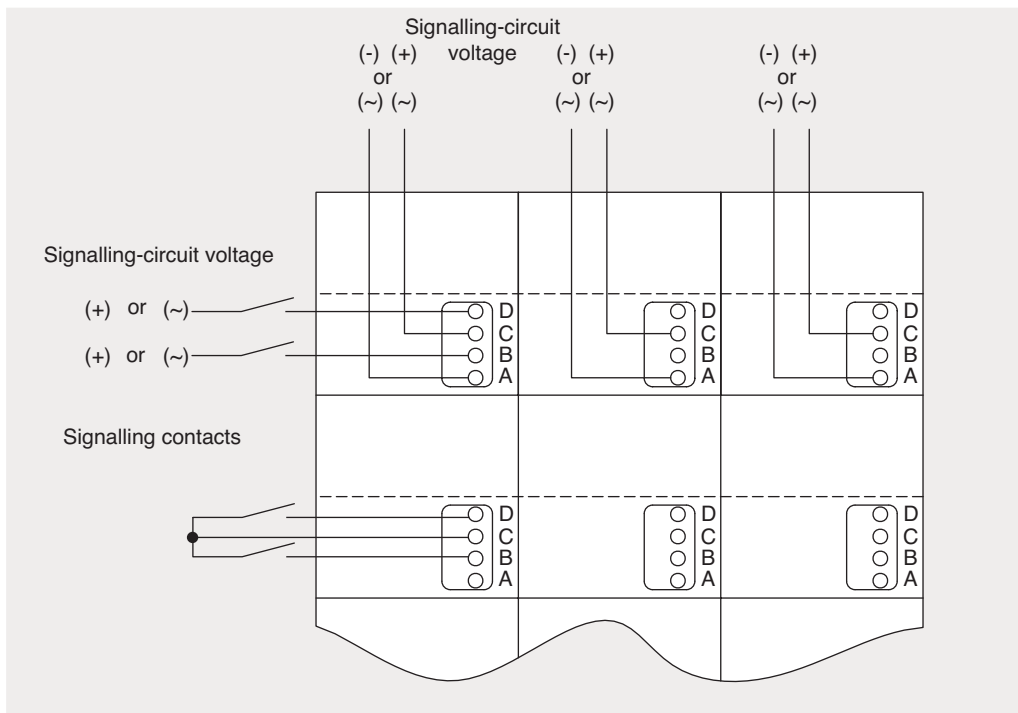

Terminals on the rear panel of the ME 3010 system

connected as follows:

- Terminals "A": to negative potential (-) of signalling voltage
- Terminals "C": to positive potential (+) of signalling voltage

This connects the signalling voltage to all modules of the same column.

The positive potential (+) of the signalling voltage is also available at the other terminals ("C") of this column.

• Message inputs at terminals:

- Terminals "B" – for the lower message field
- Terminals "D" – for the upper message field

• Terminals "C" – positive potential (+) of the signalling voltage for the supply of floating signalling contacts.

Connection of External Pushbuttons and Horn in Systems with Back-Light LED Display

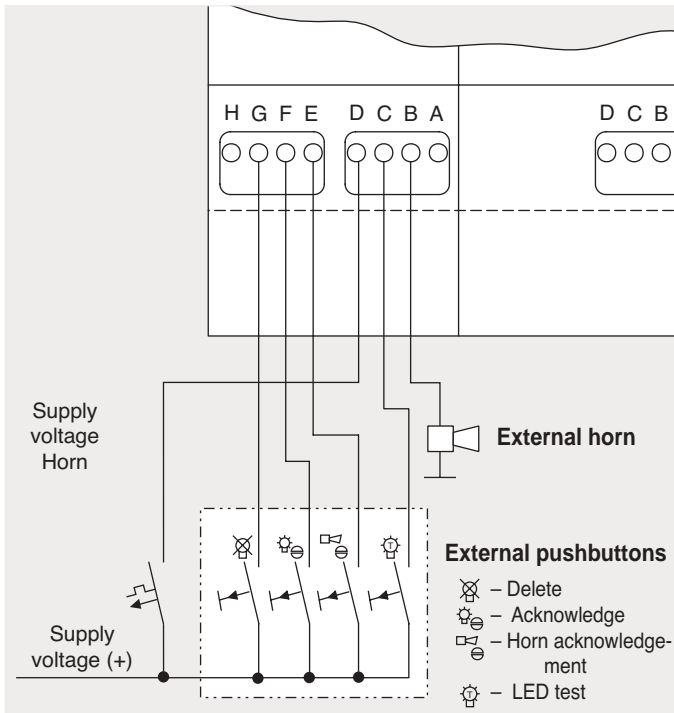

Connection of External Pushbuttons and Horn in Systems with LED Display

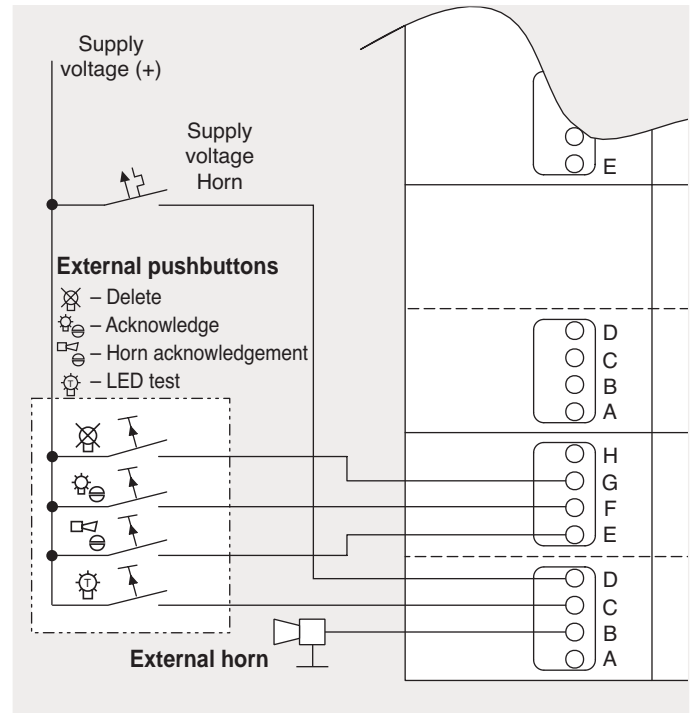

FVCC/DCF 01 Voltage Monitoring Module

This module monitors the supply voltage and uses the a.c. auxiliary voltage to indicate an undervoltage or voltage failure. The fault is indicated by an LED located on the frontplate, and by a floating change-over contact. Activating the RESET button acknowledges the fault. The voltage failure LED is reset when the supply voltage recovers or rises above the energizing threshold.

The FVCC 01/DCF 01 module combination occupies one slot. It must be specified as an option when the ME 3010 is ordered.

- AC voltage connection to terminals 3 and 4
- DC voltage connection to terminals 1 and 2
- Fault indication by means of change-over contact at terminals 5, 6 and 7
- Contact characteristics
 - Maximum voltage: 150 V d.c. (ohmic)
 - Maximum current: 500 mA (ohmic)

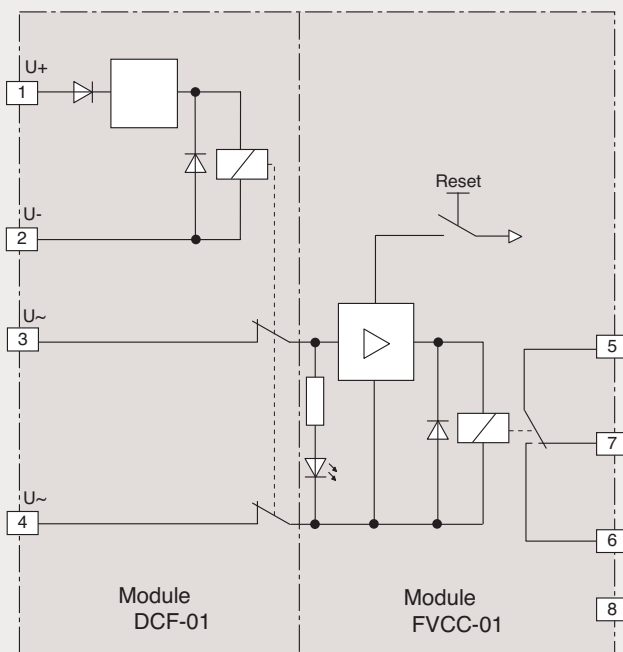

Rated Voltage	Make Voltage ±5%	Break Voltage ±5%
24 V d.c.	15 V d.c.	14 V d.c.
48 V d.c.	36 V d.c.	34 V d.c.
60 V d.c.	36 V d.c.	78 V d.c.
125 V d.c.	105 V d.c.	100 V d.c.

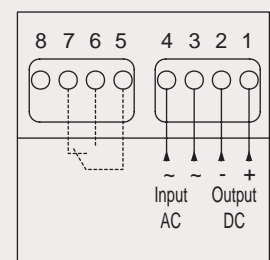
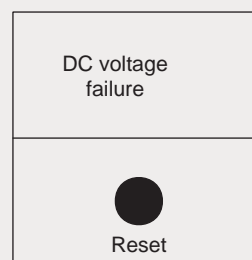

FVCC/DCF 01 voltage monitoring module (block diagram)

FVCC/DCF 01 voltage monitoring module (block diagram)

Signalling Sequence According to ISA

The following function diagram lists the ISA signalling sequences that can be applied to the ME 3010 alarm indication system. The sequences are set by means of coding jumpers on the CM 02 central processing module.

Function Diagram

Signalling sequence at new value indication													
Art ISA	Alarms	Normal	Message arriving	Acknowledged	Message going	Gone message without acknowledgement	Acknowledge	Reset	Reset LEDs				
ISA 1	visual acoustic												
ISA 1A	visual acoustic												
ISA 2A	visual acoustic												
ISA 2C	visual acoustic												
Signalling sequence at first-up indication													
Art ISA	Alarms	System state Normal	Message arriving		Mess. acknowl.		Message going		Gone message without acknowledgement		Acknowledged		Reset
			1st mess.	subsequ.	1st mess.	subsequ.	1st mess.	subsequ.	1st mess.	subsequ.	1st mess.	subsequ.	
ISA 4A	visual acoustic												
ISA 4A	visual acoustic												
		– LED off	– Flashing	SB – Fast flashing		– Horn off							
		– LED on	Q – Acknowledge	LB – Slow flashing		– Horn on							

Maintenance

ME 3010 systems do not require much maintenance. Only the acoustic and LED signal indicators must be checked for their correct functioning.

Before you can remove a message signalling module, you must pull out the front plate using a special extraction tool (see auxiliaries list). You may remove the module during online operation; there is no need to switch off the system.

When you insert a module, make sure that the printed circuit board is properly placed in the guiding grooves. Modules with LEDs must have the plug connector on the right-hand side. Modules with back-light LEDs must have the plug connector in the lower part. If a module is faulty, please return the complete module. In this way we can ensure that the repaired module and the entire system function correctly.

Status of Delivery

Prior to delivery the ME 3010 systems are configured in the factory according to the specifications stated in the customer order. If you do not specify any particular settings in your order, the ME 3010 system is delivered as follows:
 CPU module: ISA-2C, LED Test button, manual acoustic acknowledgement and integrated horn with continuous signal;
 MF2 Message signalling module: N/O energization and assigned to the group of first-up message indication;
 The signalling sequences and other settings can be modified by changing the coding jumpers or SMD jumpers.

High Voltage Test

Remove the modules from the housing before testing them. Apply the test voltage between the short-circuited terminals and the housing.
 Use a test voltage of 2 kV 50/60 Hz, for a duration of 1 minute. According to IEC 255.4, plugged-in modules allow a test voltage of 500 V 50/60 Hz, for the duration of 1 minute.

Order check list

System with LED display (page 4, 6)

LED colour: red, green or yellow
 Paper label inscription (page 6)

System with back light LED display (page 4, 6)

LED colour: red or whitish yellow

Labelling of the central processing unit (page 6)

German or English or lettering:

Labelling of the Message Signalling Module (page 6)

Laser print adhesive film or
 engraved front modules (page 6)

Number of messages (including spare)

Message processing

N/O or
 N/C activation
 Status indication only

Housing width

Housing height

Frame colour black or grey

Integrated floating make (N/O) contact for every message

(page 24, RRO, with additional terminals at the rear of the system)

Supply voltage

DC 24 V, 48 V, 60 V or other

Signalling voltage

DC 12 V, 24 V, 48 V, 60 V,
 DC 110/127 V
 AC 110/127 V

Integrated power supply (page 12)

with or without monitoring
 for up to 32 messages
 for up to 60 messages

Automatic power-up acknowledgement

(page 7)

System voltage monitoring (page 15)

Signalling method

ISA (page 16)

Pushbutton

Function: LED test or
 functional test

Horn acknowledgement

manual or automatic

Integrated horn signal

continuous or clocked

Additional relay adapters connected to the system terminals

Type
 Number of

Contact-hazard-protected rear plate (only applies to systems that have no relay adapters fitted)

CM 02 Central Processing Module

Description

The CM 02 central processing module comprises 3 function blocks that communicate with the MF2 02 message processing modules, and a large selection of signalling modes.

Flashing Generator

The tact generator TG produces two flashing frequencies: the fast flashing signal SB and the slow flashing signal LB. The downstream amplifier is capable of driving 238 signalling circuits. The fast flashing frequency is about 1.2 Hz and the slow flashing frequency is about 0.4 Hz.

Memory for the Acoustic Signal

The acoustic signal memory is activated by incoming messages sent by the message processing modules. After 5 seconds it can be reset manually or automatically. The reset mode is selected by means of the coding jumpers on the p.c.b. The output of the memory operates a relay whose floating N/O contact is connected to the "D" and "B" terminals at the rear panel, and the internal horn which emits a continuous or discontinuous acoustic signal.

First-Up Memory

The first-up memory can be selected if processing of first-up values is required for all messages. This group of first-up processing has a capacity of 238 messages. The signalling sequence is selected by means of coding jumpers. The first incoming message is indicated by a fast flashing light. All subsequent messages are indicated by a static light. After acknowledgement the light stays on as long as the message is pending. However, if the event is a sporadic event then the light extinguishes after acknowledgement. This signalling sequence is repeated when a new message arrives.

With signalling sequences ISA-1, ISA-1A, ISA-4A without reset, the acknowledgement function for the LEDs has the same effect as the delete function.

The central processing module normally has 4 function buttons on its front plate. One pushbutton each:

for the acknowledgement of the acoustic signal, 

for the acknowledgement of the LED display, 

for the LED test, 

and for the delete function. 

The LED test pushbutton may be changed into a function test button. All functions can also be implemented by means of external pushbuttons that are connected to the terminals on the rear plate.

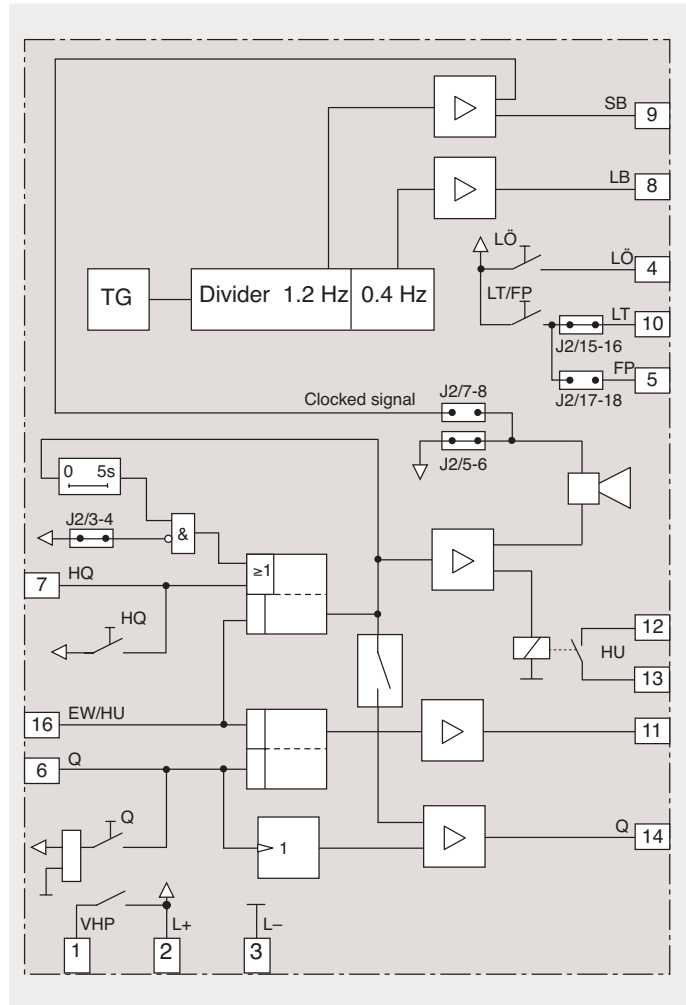

Additional Functions (available on request):

- Unattended mode (sleep mode)
- Automatic LED acknowledgement
- Chained for the acknowledgement of the LED display and the acknowledgement of the acoustic signal
- RUN indication
- Indication of simple remote operation
- 2 horns (2 CM 02 central processing modules) with or without switch-off

Technical Characteristics

Voltage	24V	48V	60V
Current consumption			
Terminal 2	90 mA	90 mA	90 mA
Switching capacity			
Terminals 12,13 (horn contact)	75 V/500 mA		
Flashing frequency			
Terminal 8: slow flashing		0.4 Hz	
Terminal 9: fast flashing		1.2 Hz	
Automatic acknowledgement for acoustic signal			
Terminals 12,13		5 sec	

Horn

Volume	90 dB at a distance of 10 cm
Frequency	4 kHz

Coding socket J2 on the central processing module

Example: manual acknowledgement of acoustic signal	Inserted jumpers: 3-4
integrated horn with continuous acoustic signal	Inserted jumpers: 5-6
ISA-2C signalling sequence	Inserted jumpers: 13-14
LED Test pushbutton	Inserted jumpers: 15-16

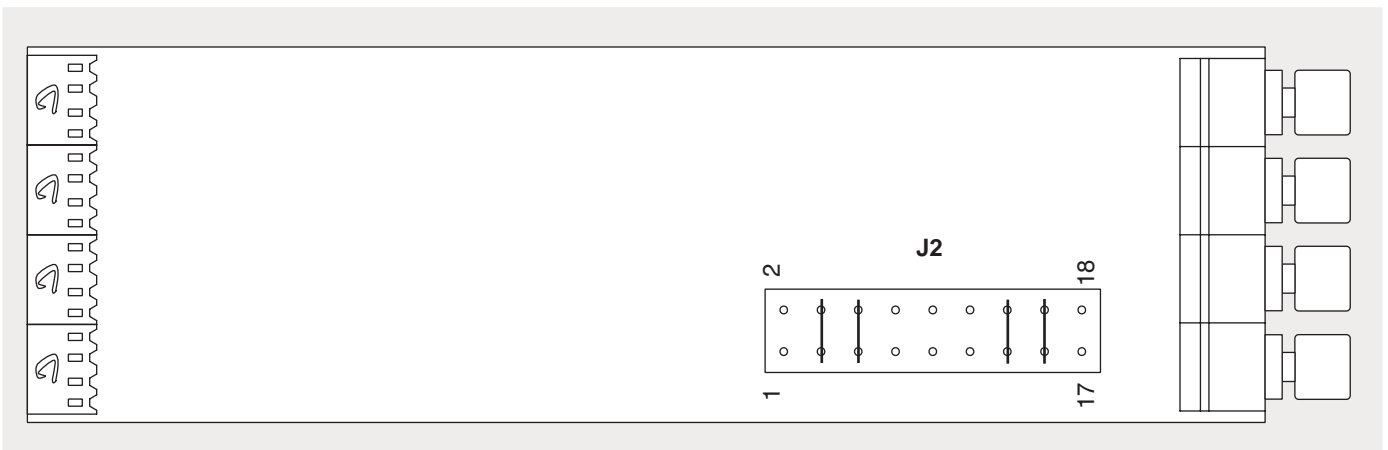

Setting the functions of the CM 02 CPU module with the J2 coding jumpers

		A	B	C	D	E	F	G	H	I
Function	(coding socket) J2	1-2	3-4	5-6	7-8	9-10	11-12	13-14	15-16	17-18
Sequence	ISA-1									
	ISA-1A									
	ISA-2A									
	ISA-2C									
	ISA-4A.									
	ISA-4A C/RESET									
Pushb.	LED test									
	function test									
Horn acknowl.	Manual acknowledgement									
	Autom. acknowl. after 5s									
Integral horn	Continuous signal									
	Clocked signal									

Setting the ISA signalling sequence and other functions. On customer request, the functions are set in the factory prior to delivery.

MF2 02 Message Signalling Module

Description

The MF2 02 message signalling module has two inputs for message signals and two LED displays. The message signal inputs can be set to N/O or N/C energization. In addition you select for every message signal input, whether or not it should be assigned to the group of first-up signals (see page 18, "CM 02 Central Processing Module").

The messages are visually indicated by one of two different methods:

- Back-light LED display:
The front module is made of semi-transparent white acrylic glass that covers two groups of high-intensity LEDs. The meaning of the message is either engraved directly in the front plate, or printed on a stick-on label.
- LED display:
Each messages is indicated by a 5mm round LED. The LEDs are located on the left-hand side of the front plate. The LED colours are selectable (red, green, yellow). The meaning of the message is typed or hand-written on a paper label that can be inserted in a transparent pocket adjacent to the LED.

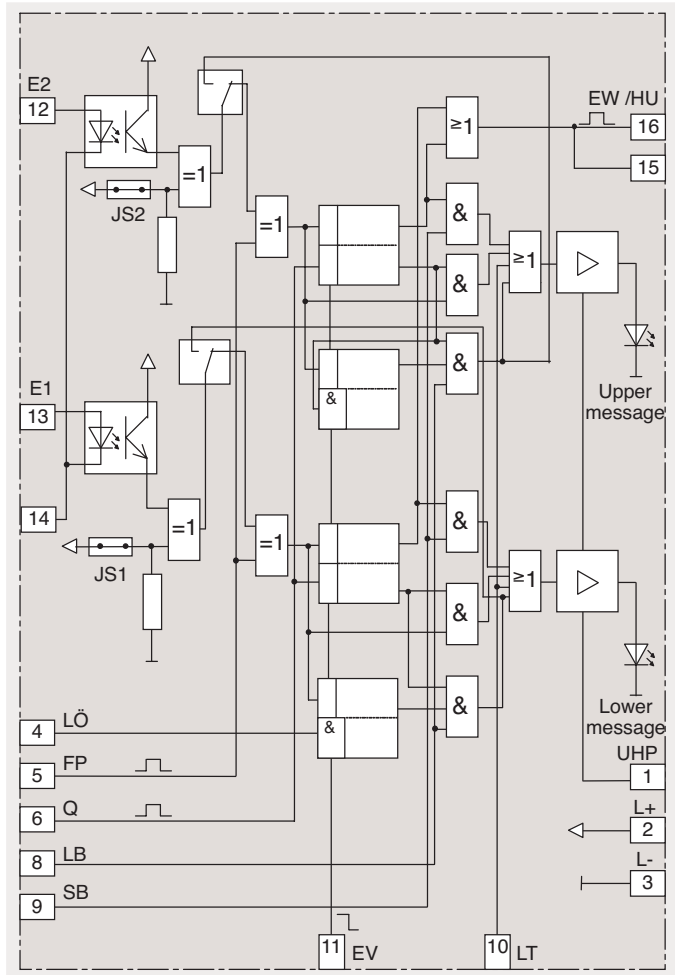

Technical Characteristics

Voltage	24 V	48 V	60 V
Current consumption			
Terminal 1			
Back-light LED display	70 mA	70 mA	70 mA
LED display	70 mA	70 mA	70 mA

Addition Functions (available on request):

- Status messages without alarm indication

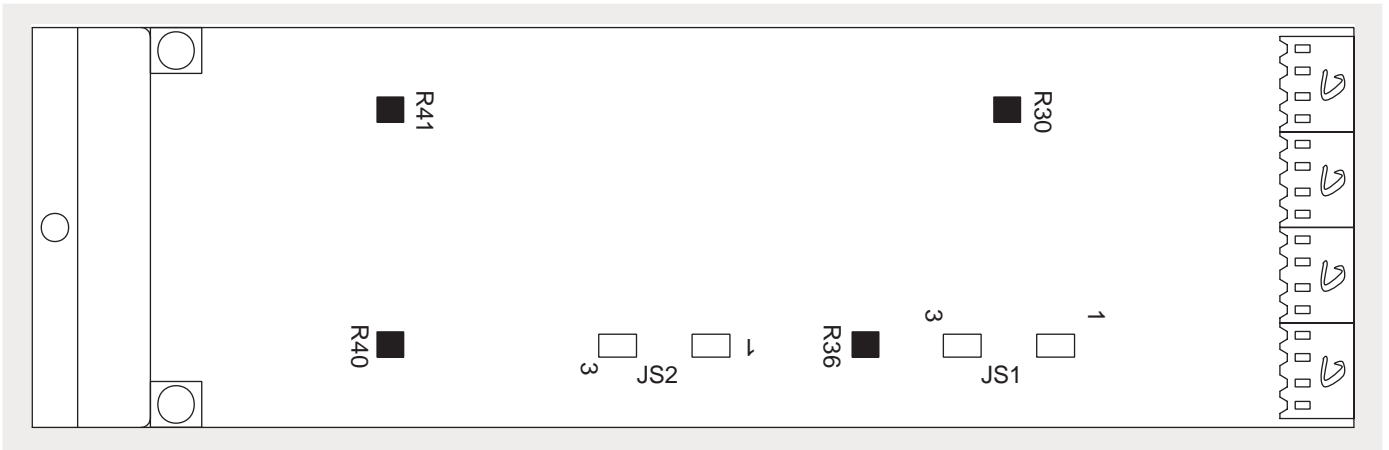

CHANNEL	CHANNEL E1 Terminal B Lower message				CHANNEL E2 Terminal D Upper message			
	JS2		R41	R36	JS1		R40	R30
RESISTOR 0R	1-2	2-3			1-2	2-3		
WITH SEQUENCE	OR		OR		OR		OR	
SIGNALLING ONLY		OR			OR			
N/O CURRENT ENERGIZATION				OR				OR
N/C CURRENT ENERGIZATION								

Legend	
OR	SMD- Resistor '0' Ohm

The operation modes can be set in the factory prior to delivery, if requested

Insertable Switching Power Supply IPS 0.

Description

The insertable switching power supply unit supplies the modules with a direct voltage of 24 V. The unit's input voltage can be d.c. or a.c. and can lie in a wide range.

The power supply unit occupies one module slot. It is inserted in the ME 3010 housing from the front. Its connections are made at the terminals on the rear panel.

The IPS 0. power supply unit supplies the logics of the ME 3010 system, the LEDs, the horn and the horn relay, and external components, if required.

• Please note:

Housings with integrated IPS switching power supply need to have a minimum size: (V= vertical, H=horizontal)

- Alarm indication systems with back-light LEDs: 4 V x ___ H
The supply module occupies the slot above the CPU module (see dimension diagram on page 8).
- Alarm indication systems with LEDs: ___ V x 2 H.
The supply module occupies the slot next to the CPU module (see dimension diagram on page 10).

Technical Characteristics

Supply voltage	DC: 100 to 275 V, or AC: 90 to 264 V
Output voltage	24 V d.c.
Output current IPS-01 - for up to 32 messages	1 A
Output current IPS-02 - for up to 60 messages	1.6 A

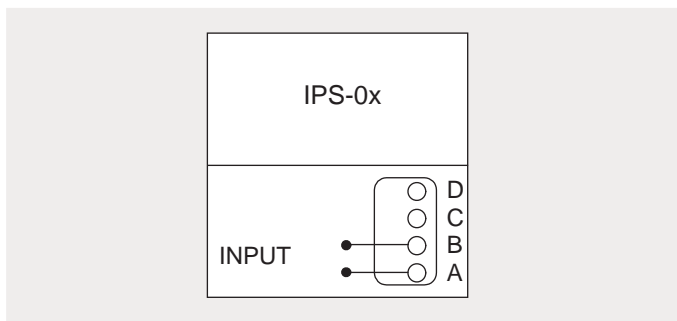
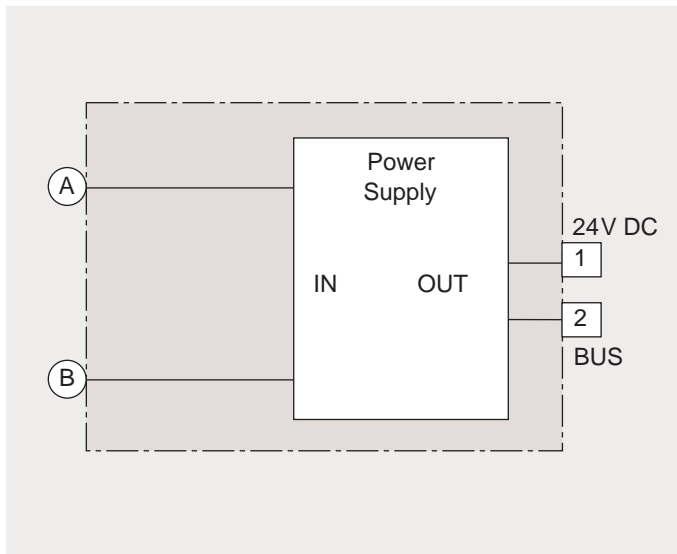

Terminals on the rear panel of the ME 3010 system

Insertable Switching Power Supply IPS 1.

Description

The insertable switching power supply unit supplies the modules with a direct voltage of 24 V. The unit's input voltage can be d.c. or a.c. and can lie in a wide range.

In addition, the IPS 1. unit can act as a voltage backup, e.g. for a central battery. If the voltage of the d.c. source falls below a defined limit, the IPS 1. unit switches over to an a.c. supply until the d.c. voltage has recovered above the defined limit. The failure of the d.c. or a.c. voltage source is indicated by one fault signalling contact each.

The power supply unit occupies one module slot. It is inserted in the ME 3010 housing from the front. Its connections are made at the terminals on the rear panel.

The IPS 1. power supply unit supplies the logics of the ME 3010 system, the LEDs, the horn and the horn relay, and external components, if required.

Monitoring

The monitoring circuit determines whether the voltage present at the terminals is a d.c. or an a.c. voltage. Faults are indicated by floating N/C contacts.

The main supply comes from a d.c. voltage source. If this voltage is missing, the unit automatically switches over to an auxiliary a.c. voltage. The return to normal upon recovery of the d.c. voltage is automatic, too.

Technical Characteristics

Supply voltage DC: 100 to 275 V and/or
AC: 90 to 264 V

Output voltage 24 V d.c.

Output current IPS 11
- for up to 32 messages 1 A

Output current IPS 12
- for up to 60 messages 1.6 A

Floating N/O contacts
Monitoring: AC failure 500 mA/75 V
Monitoring: DC failure 500 mA/75 V

Switch-over according to the following table

Rated Voltage	Make Voltage ±5%	Break Voltage ±5%
110 V d.c.	80	78
125 V d.c.	105	100
220 V d.c.	193	189

• Please note

Housings with integrated IPS switching power supply units must have a minimum size:

- Alarm indication systems with back-light LEDs: 4 V x ___ H
The supply module occupies the slot above the CPU module (see dimension diagram on page 8).
- Alarm indication systems with LEDs: ___ V x 2 H.
The supply module occupies the slot next to the CPU module (see dimension diagram on page 10).

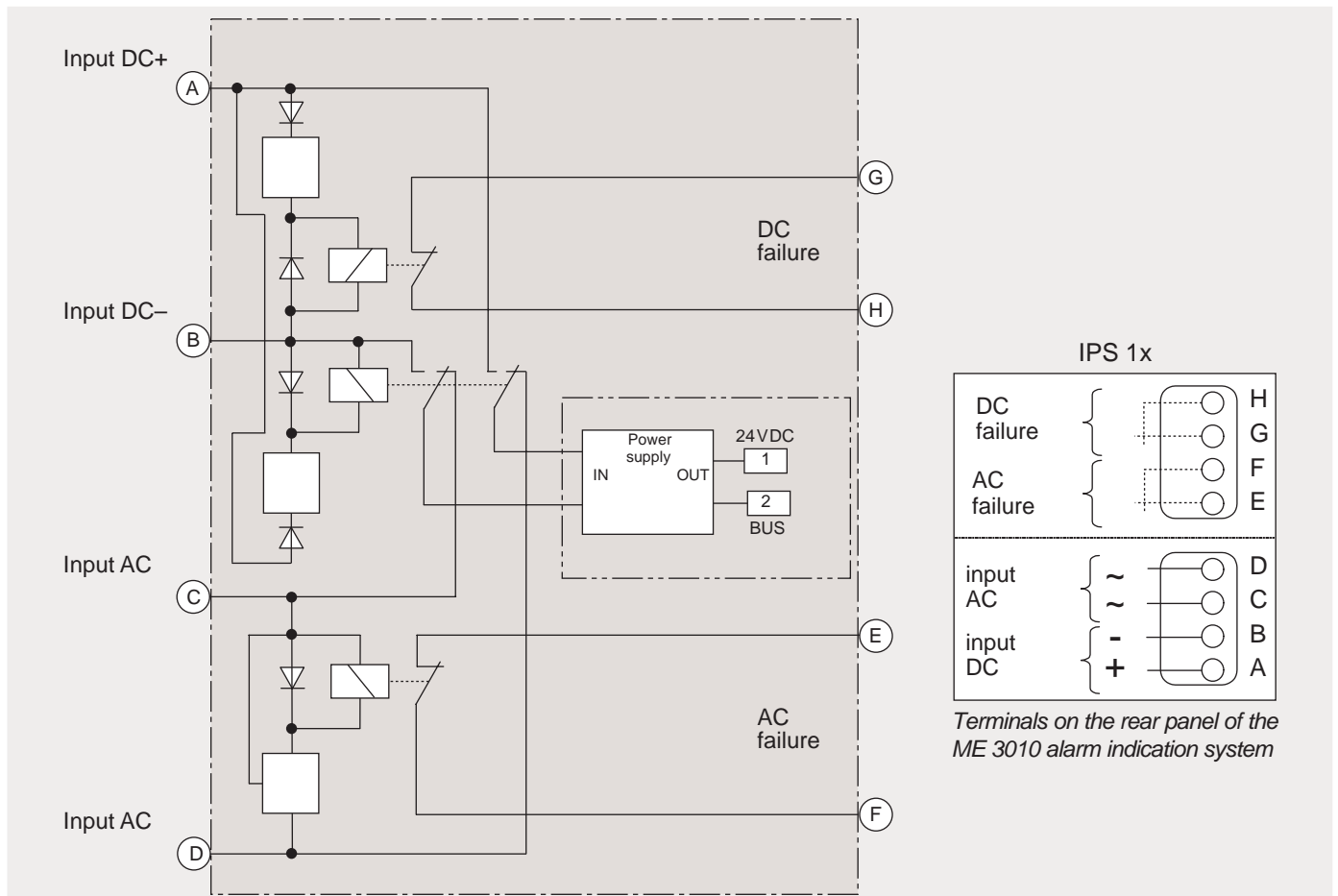

Terminals on the rear panel of the ME 3010 alarm indication system

Additional Contacts

RRO Auxiliary Contacts

RRO are integrated relays that can be connected to slots designated for message signalling modules. Please specify with your order. 1 N/O contact for each message

- Contact characteristics
 - Maximum voltage: 150 V d.c. (ohmic)
 - Maximum current: 500 mA (ohmic)

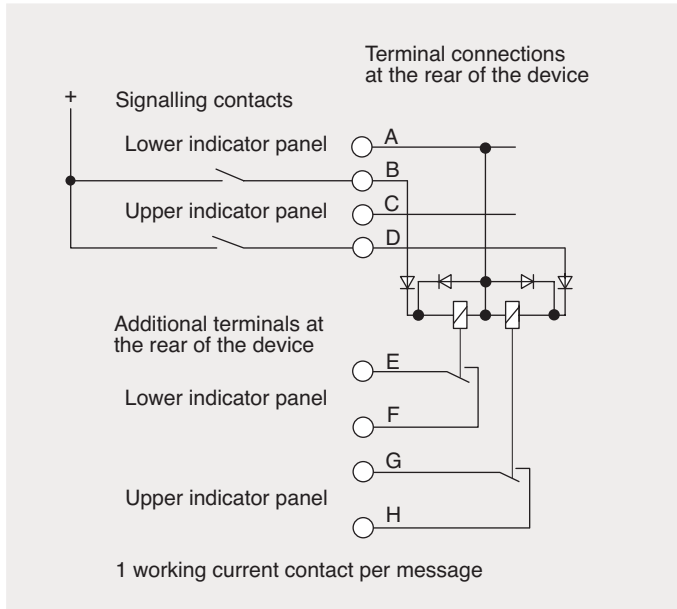

Circuit diagram of the RRO integrated relays

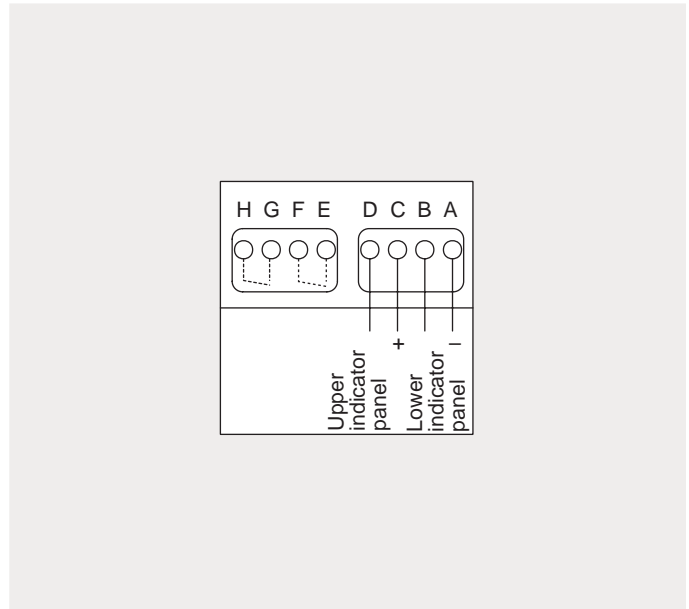

Terminals on the rear panel of the ME 3010 system

Relay Adaptor RV2 .., each for 2 messages, connected to the rear terminals

RV2 01 relay Adaptor, for 2 messages, 1 N/O contact for each message

- Contact characteristics
 - Maximum voltage: 150 V d.c. (ohmic)
 - Maximum current: 500 mA (ohmic)

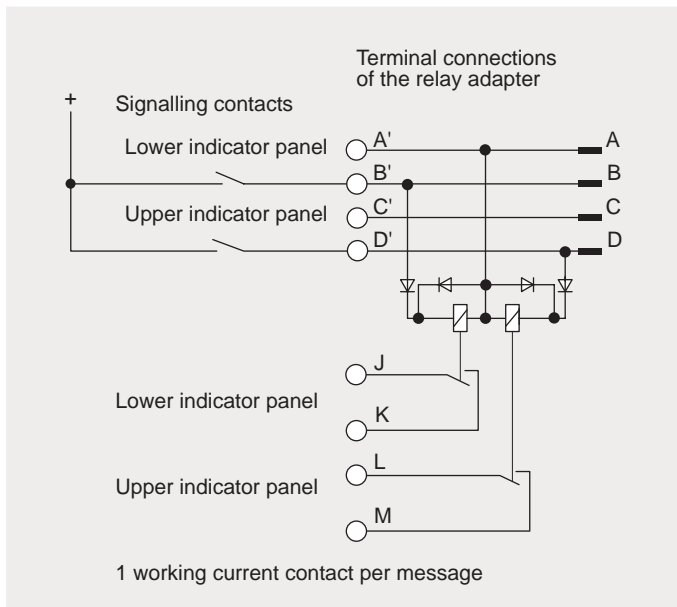

Circuit diagram of the RV2 01 relay adaptor

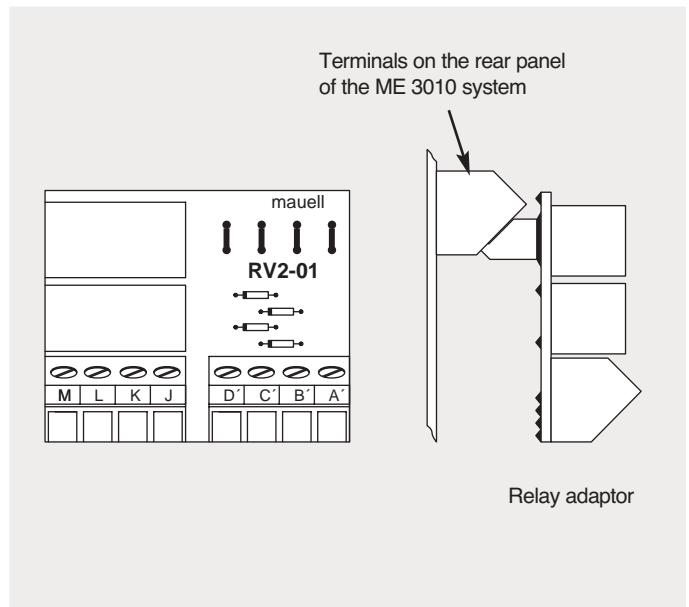

Terminals of the relay adaptor

RV2 13 Relay Adaptor

for 2 messages, 1 change-over contact for each message

- Contact characteristics
 - Maximum voltage: 150 V d.c. (ohmic)
 - Maximum current: 500 mA (ohmic)

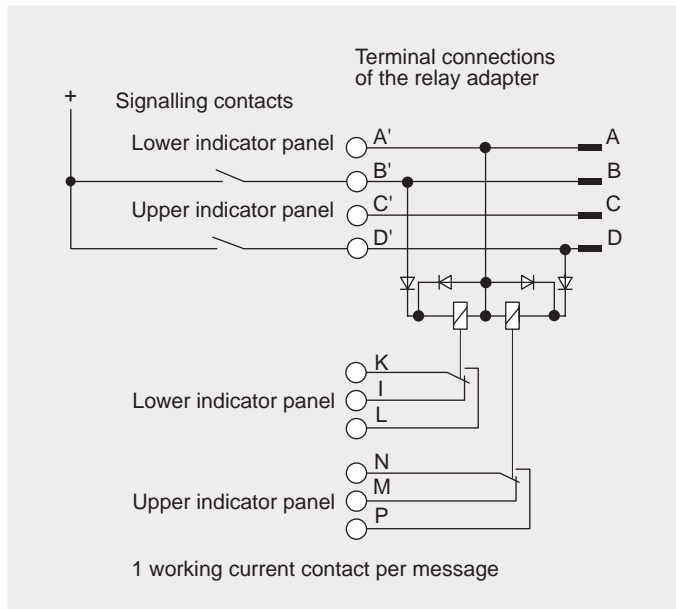

Circuit diagram of the RV2 13-1 relay adaptor

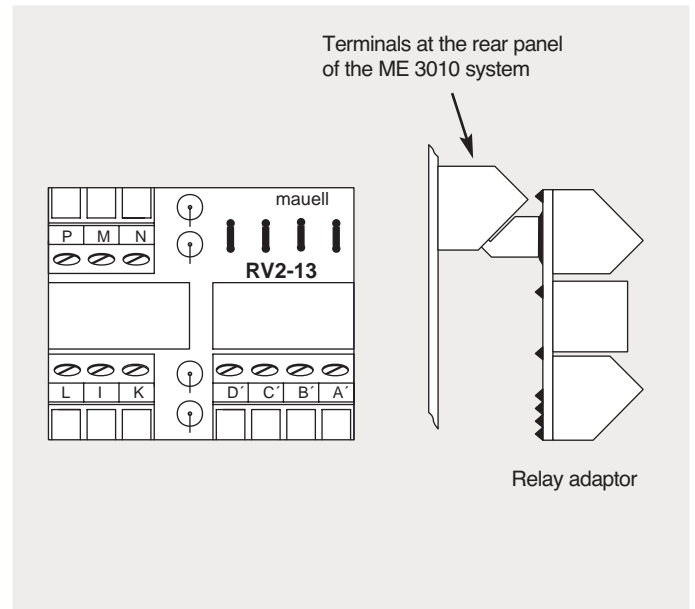

Terminals of the relay adaptor

RV2 21 Relay Adaptor

for 2 messages, 2 N/O contacts for each message

- Contact characteristics
 - Maximum voltage: 150 V d.c. (ohmic)
 - Maximum current: 500 mA (ohmic)

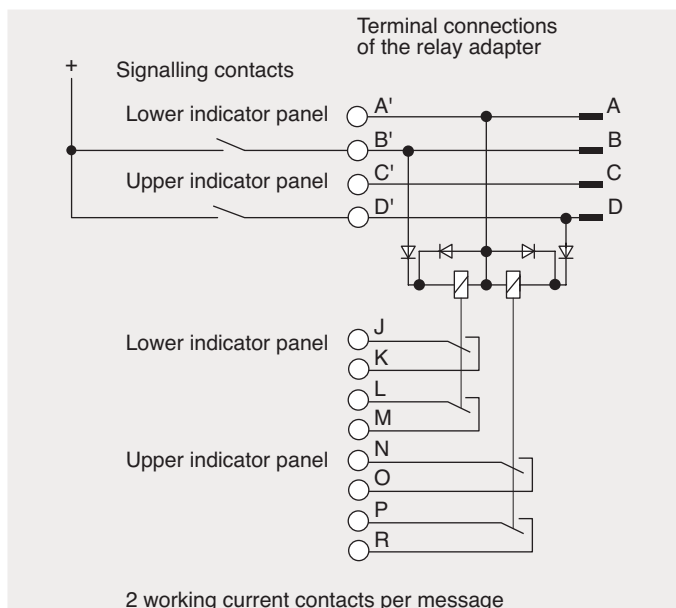

Circuit diagram of the RV2 21-2 relay adaptor

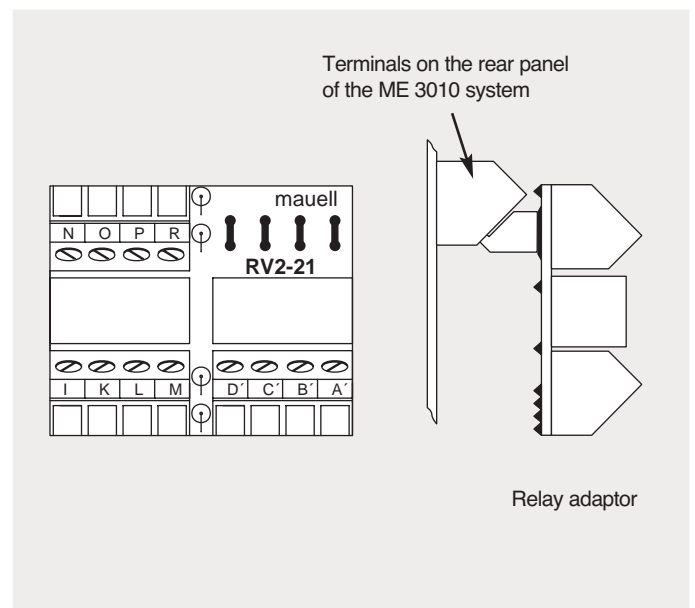

Terminals of the relay adaptor

RV2 14 relay adaptor, for 2 messages

1 monostable N/O contact for each message, pulse duration: 80 msec to 150 msec approx.

- Contact characteristics
 - Maximum voltage: 150 V d.c.(ohmic)
 - Maximum current: 500 mA (ohmic)

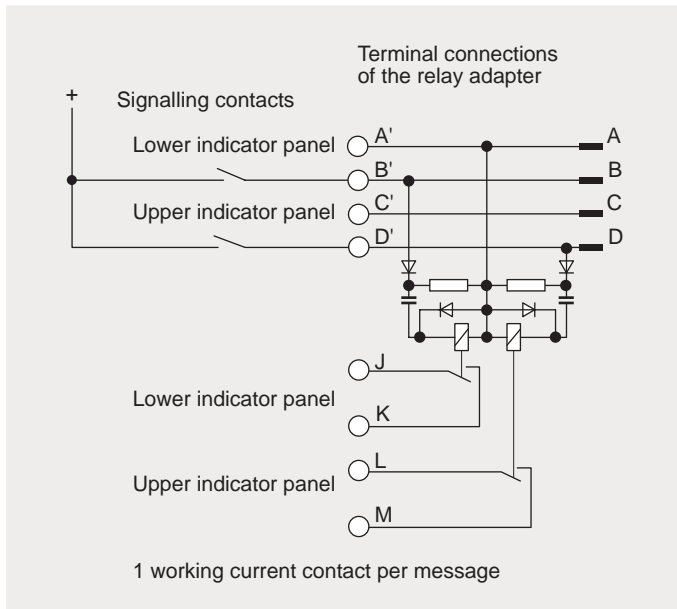

Circuit diagram of the RV2 14 relay adaptor

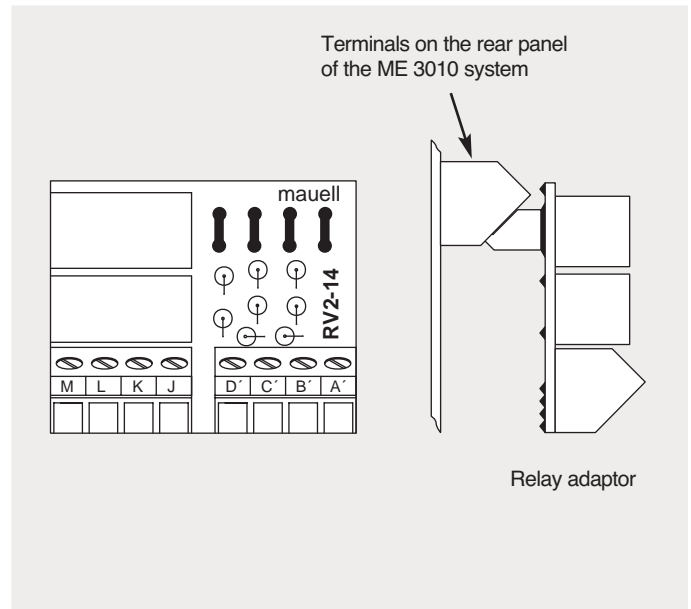

Terminals of the relay adaptor

RV2 02 Relay Adaptor

for 2 messages, electrical isolation from the system for each message

- System isolated voltage
 - Input voltage: 24, 48 or 60 V d.c., other voltages on request
 - Input current: 12, 6 or 5 mA approx.

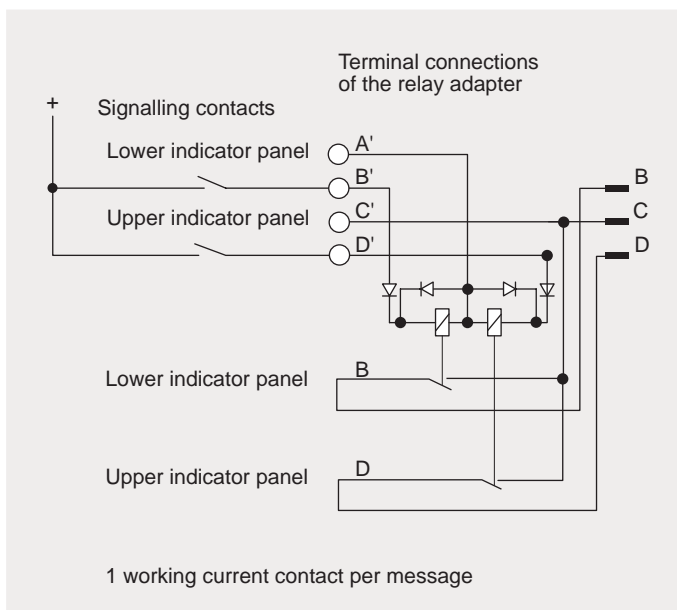

Circuit diagram of the RV2 02 relay adaptor

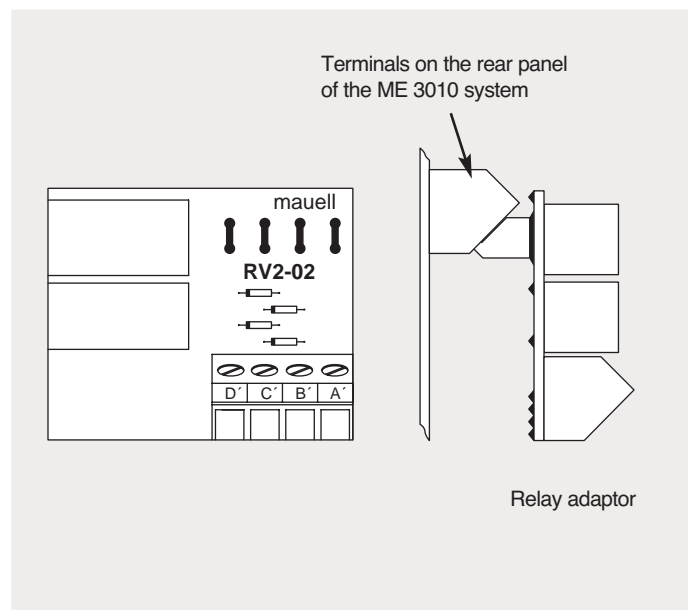

Terminals of the relay adaptor

Representatives

Germany

Helmut Mauell GmbH

Am Rosenhügel 1 – 7

D-42553 Velbert

Tel.: +49 (0)20 53/1 30

Fax.: +49 (0)20 53/1 36 53

Internet: www.mauell.com

E-Mail: info@mauell.com

For an up-to-date list of all our representatives and branch offices, please visit our homepage: www.mauell.com

Representatives and Branch Offices

All Over The World:

Abu Dhabi U.A.E.	Iran
Argentina	Korea
Austria	Kuwait
Belgium	Netherlands
Brazil	Norway
Czech	Poland
Republic	Singapore
Denmark	Spain
Finland	Sweden
France	Switzerland
Great Britain	Turkey
Hungary	USA

mauell
*... your partner
in automation*

