

ME30 *compact*



ME30 compact For decentralized monitoring and control of distributed technological processes

ME30 compact Capable of processing measured and count values, control commands, setpoint inputs, status informatio, alarm messages, etc.

ME30 compact Offers versatile telecontrol technology
Connects the distributed operator stations with the control center

ME30 *process IT*

Fields of Application

ME30 compact is particularly suitable for the following fields of application:

- Electricity, gas, water and district heating supply networks
- Power supply, distribution, monitoring and management
- Environmental technology
- Waste water treatment and disposal
- Pipelines
- Well engineering and water supply
- Traffic control
- Signalling installations
- Industrial plants
- Traction supply lines
- Weather stations
- Sluices
- Radio masts
- Wind power and hydroelectric plants
- Building services control

Apart from the conventional functions, such as the acquisition, transmission and output of data, the ME30 *compact* device offers a variety of additional functions:

- Data preprocessing in order to reduce the load on data traffic
- Automation by means of PLC functions, e.g., for operating sequences, interlocking, control programs, monitoring and closed-loop control functions
- Integration of different telecontrol protocols and modules, such as
IEC 60870-5-101 and 3964R/RK512, SEAB 1N
via RS 232 or modem connections
Ethernet connections (TCP/IP)
CANopen protocol
Other protocols on request
Radio links (GSM, closed-circuit radio data transmission)
Fiber optics connections

ME30 *compact* is the compact system of the ME30 *process IT* system family. It offers all functions necessary for distributed process automation. It can be easily expanded and is part of the consistent system concept of the ME30 product family.

In combination with the ME30 *telmatic*, ME30 *infobox* and ME30 *infoview* systems, it allows the design of easy expandable modular systems with a high degree of application flexibility.

The PLC functions are programmed according to DIN EN 61131-3 using the configuration tool CANopen Studio.

The system's compact modules for the acquisition and transmission of process data can be organized in different configurations to find the optimal and most economical solution for the automation task to be solved.

Information Quantity

Specifications of the ME30 *compact* devices:

- 16 message inputs
- 8 command outputs
- 8 measured value inputs
- 2 measured value outputs
- 2 transmission / trunk line interfaces
- 2 interfaces
 - For the configuration of the ME30 *compact*
 - For the expansion with ME30 *telmatic* I/O submodules

Process inputs and outputs and the power supply are connected to the receptacles in the lower part of the housing. These COMBICON receptacles allow fast connection or disconnection of the device from the process.

The transmission and trunk line interfaces can communicate with different modem types and allow CANopen, Ethernet or fiber optics connection. The connection is established by means of 9-pin Sub-D, fiber optics or RJxx sockets located on the front of the device.

LED displays on the device's faceplate indicate the states of the controller.

The states of the message inputs DI 1-16 and command outputs DO 1-8 are indicated by means of LEDs.

The communication is based on the IEC 60870-5-101 telecontrol protocol.

Software

- Firmware and parameters are stored in the flash EPROM and EEPROM
- PLC functions are programmed acc. to DIN EN 61131-3
- Time synchronization can be carried out via the internal clock, DCF77 or external GPS clock
- 1 ms real-time stamp

Parameter Assignment and Service Programm CANopen Studio

The powerful configuration, parameter assignment and diagnosis tool CANopen Studio is used for all modules of the ME30 system family.

Essential features of CANopen Studio:

- Runs under Win 95/98/2000/ME/XP/NT4.0 SP5, minimum requirements: 400 MHz and 64 MB RAM
- User-friendly and application-oriented software handling by means of plug-ins
- Intuitive configuration by means of colour graphics and consistent use of menus and dialogs
- PLC programming acc. to DIN EN 61131-3
- Password-protected access
- Defining the parameters of all essential functions of the ME30 system family
- Local parameter assignment and diagnosis using the module's configuration interface
- Remote parameter assignment and diagnosis, for example, by employing a Web server (Internet/Intranet)
- The configuration data and parameters are stored on a plug-in Mauell flash disk so that they can be exchanged quickly and easily

The Reliability Concept of ME30 *compact*

Rugged design, a high degree of availability, and functional reliability - these are the outstanding features of our ME30 product line.

The ME30 system family is the result of Mauell's many years of experience in the design and manufacture of process control and telecontrol systems, used amongst others, by power generation and supply companies.

The high demands of the utility industries were the basis for the design of the ME30 *compact* module and system software.

The characteristics of the ME30 *compact* system:

- Comprehensive self-monitoring function
- Indication of all essential operating states and functions
- Interference immunity acc. to EMC guidelines 89/336/EWG
- Floating inputs and outputs
- Configuration of all command, message, measured value, closed-loop and monitoring functions
- Hardware designed for maintenance-free operation and long service life

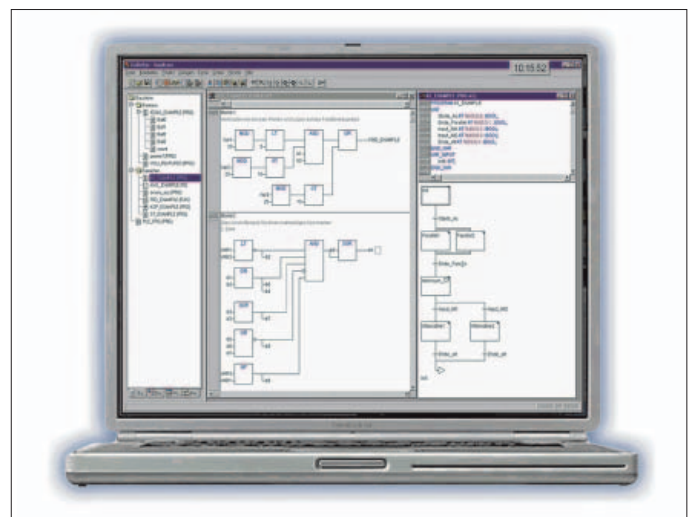



Interfaces, Control and Display Elements

• Configuration interface

Sub-D plug connector for the configuration of the device

• Interface A

Sub-D plug connector for RS 232 or CAN interface

• Interface B

Sub-D plug connector for RS 232 or CAN interface; RJ12 or RJ45 socket for modem, ISDN or Ethernet connection, or fiber optics connector for multi-mode glass fiber connection

• Interface for the connection of I/O modules

I/O SUB-bus connector for the expansion with I/O submodules of the ME30 *telmatic* system

LEDs

- | | |
|-----------|-------------------------------|
| • Ready | Device ON |
| • Error | Fault |
| • Status | Application program status |
| • DI 1-16 | Message inputs 1-16 |
| • DO 1-8 | Message / command outputs 1-8 |

Control elements

- 2 rotary coding switches for setting the module address and parameters (left = high-order part, right = low-order part)

Modules

- Flash disk as storage medium for firmware and application software

Technical Characteristics

Supply voltage	24 VDC
Power consumption	< 9 W
Processing unit	
Processor	SAF C167
Flash EPROM	1 MB
EEPROM	32 KB
Backup battery	72 h (Gold Cap) for hardware clock, event and error memory

Transmission protocols

Interface A	CANopen or 3964R/RK 512
Interface B	CANopen or 3964R/RK 512, IEC 60 870-5-101, IEC 60 870-5-104, SEAB 1N

Transfer methods

Point-to-point operation	
Point-to-multipoint operation	
Subscriber dialing	Analog modem, ISDN, GSM

Modem types / transmission standards

Type A

Leased line (4-wire) or dial line (2-wire), 2,400 bps max.

Transmission standards	
V.22 bis	2,400 bps FDX
V.22	1,200 bps FDX
V.21	300 bps FDX
V.23	1,200 bps HDX

Type B

Leased line (2-wire), 2,400 bps max., point-to-point or point-to-multipoint operation (waystation operation)

Transmission standards	similar to Type A
------------------------	-------------------

Type D

Leased line, 33,600 bps max. (2-wire) for point-to-point operation

Transmission standards	
V.34+	33,600 bps FDX
V.34	28,800 bps FDX
V.32 bis	14,400 bps FDX
V.32	9,600 bps FDX
V.22 bis	2,400 bps FDX
V.22	1,200 bps FDX
V.21	300 bps FDX

Type E

Dial line, 33,600 bps max. (2-wire)

Transmission standards	similar to Type D
------------------------	-------------------

Type F

ISDN dial line 64,000 bps

Transmission standards	
V.110 asynchronous	
HDLC async to sync conversion (PPP asynchronous)	
HDLC transparent (octets are packed into HDLC frames)	
Byte transparent (raw B channel data)	
X.75-NL	
V.120	

Message inputs

Number	16	
Nominal voltage	24 VDC to 220 VDC	
Connection	common root for groups of 4, floating	
Electrical isolation	by means of opto-couplers	
Electric strength	acc. to VDE 0435, Part 303, Class 3 and DIN EN 60870-2-1, Class VW3	
Suppressor circuit	acc. to EN 61000-6-2	
Message types	Single and double messages, transient information and count pulses ≤ 100 Hz, count value 24 bit, all messages are interrupt-controlled	
Signal acquisition	1 ms minimum period	
Time resolution	1 ms	
Filter time	typically 0.25 ms, definable up to 250 ms	
Command input operating points		
Type	Signal	Voltage range
24 VDC	0-signal	0-5 V (0-20 %)
	1-signal	15-30V (62-125 %)
Power consumption of a 24 V input	typ. 5 mA	

ME30 *process IT*

Command outputs

Number	8
Nominal voltage	24 VDC to 220 VDC
Suppressor circuit	acc. to EN 61000-6-2
Types of commands	2-pole command output

Relay Outputs

Connection	common root for groups of 2, floating,
Switching voltage	230 VAC/220 VDC max.
Making capacity	1,000 VA
Breaking characteristics	220 VDC/0.2 A (ohmic)
Nominal current	5 A
Peak current	30 A for 0.5 s
Operating cycles	>30 x 10 ⁶

or semi-conductor outputs

short circuit proof, polarized, common root for groups of 2, floating, plus (+) switching

Switching voltage	12 to 30 VDC max.
Load current	2 A max.

Analog inputs

Number	8
Current	0/4 to 20 mA
Connection	2-pole input, 8th group floating
Measured value conversion	Successive approximation
Suppressor circuit	acc. to EN 61000-6-2
Resolution	12 bits
Accuracy	±0.1 % at 25 °C

Analog outputs

Number	2
Range	0/4 to 20 mA
Connection	2-pole, floating
Load	500 Ω, short circuit proof
Resolution	12 bits
Accuracy	±0.1 % at 25 °C

Weight

1.8 kg approx.

Mechanical design

Metal and plastic housing for Din rail mounting
ME30 *compact* WxHxD: 260 mm x 130 mm x 141 mm

Interference immunity

DIN EN 61000-4-2:96-03	ESD; 4 kV contact discharge, 8 kV air discharge (only in conjunction with housing)
DIN EN 61000-4-3:97-08	EM-RF field; 10 V/m
DIN EN 61000-4-4:96-03	Burst; 2 kV, severity 4
DIN EN 61000-4-5:96-09	Surge; 0.5 kV symmetrical/1.0 kV asymmetrical
DIN EN 61000-4-6:97-04	RF supply; 3 V
DIN EN 61000-4-8:94-05	50 Hz magnetic fields; 30 A/m, permanent field, 100 A/m short period
DIN V ENV 50204:96-02	EM-RF field of digital radio telephones: 10 V/m

Interference emission

EN 55011	Radio interference; Group 1, Class A
----------	--------------------------------------

Ambient conditions

Storage temperature range	-40 °C to +70 °C
Operating temperature range	0 °C to +55 °C
Humidity class	3K3 acc. to DIN EN 60721-3-3

Mechanical strength test

Fc acc.to IEC 68-2-6:	2 g/±0.15 mm/10-150 Hz 3 x 20 cycles, variable frequency 1 octave/min, vibration at operation
Eb acc.to IEC 68-2-29:	10 g/6 ms/3 x 4,000 impacts

Maximum cross-sectional area of connecting cables

Single-core conductor	2 x 1.5 mm ² 1 x 2.5 mm ²
Finely stranded conductor	2 x 1.5 mm ² with connector sleeve acc. to DIN 46 228

Device versions

Available I/O

Modules M01 0000 ... M15 32EN

Process connections: plug-in connections (Combicon)

- 16 digital inputs 24V DC, input current 5 mA, floating, common root for groups of 4
- 8 relay outputs, common root for groups of 2, floating, 230 V AC/5 A max., 220 V DC/0.2 A (ohmic load)
- 8 analog inputs 0/4 ... 20 mA, bipolar input, 12-bit resolution
- 2 analog outputs 0/4 ... 20 mA, 12-bit resolution

Modules M51 0000 ... M65 32EN

Process connections: plug-in connections (Combicon)

- 16 digital inputs 24 VDC, input current 5 mA, floating, common root for groups of 4
- 8 digital transistor outputs, plus (+) switching 12 to 30 V DC, common root for groups of 2, floating, short-circuit-proof and polarized, maximum load current: 2 A
- 8 analog inputs 0/4 ... 20 mA, bipolar input, 12-bit resolution
- 2 analog outputs 0/4 ... 20 mA, 12-bit resolution

Available Interfaces

Module type	Communication interfaces		Configuration interface ^{*1}	I/O expansion interface ^{*2}
	Interface A	Interface B		
M01 0000 / M51 0000	-	-	x	x
M02 00CN / M52 00CN	-	CAN	x	x
M03 0032 / M53 0032	-	RS232	x	x
M04 00MO / M54 00MO	-	Modem Type A ... F	x	x
M05 00FO / M55 00FO	-	Fiber optics	x	x
M06 00EN / M56 00EN	-	Ethernet	x	x
M07 CNCN / M57 CNCN	CAN	CAN	x	x
M08 CN32 / M58 CN32	CAN	RS232	x	x
M09 CNMO / M59 CNMO	CAN	Modem Type A ... F	x	x
M10 CNFO / M60 CNFO	CAN	Fiber optics	x	x
M11 CNEN / M61 CNEN	CAN	Ethernet	x	x
M12 3232 / M62 3232	RS232	RS232	x	x
M13 32MO / M63 32MO	RS232	Modem Type A ... F	x	x
M14 32FO / M64 32FO	RS232	Fiber optics	x	x
M15 32EN / M65 32EN	RS232	Ethernet	x	x

- = interface not available

x = interface available

^{*1} = CAN configuration interface (9-pin Sub-D)

^{*2} = expansion interface for the I/O submodules of the ME30 telmatic product family

ME30 process IT

ME30 compact block diagram (e. g. device version M12 3232)

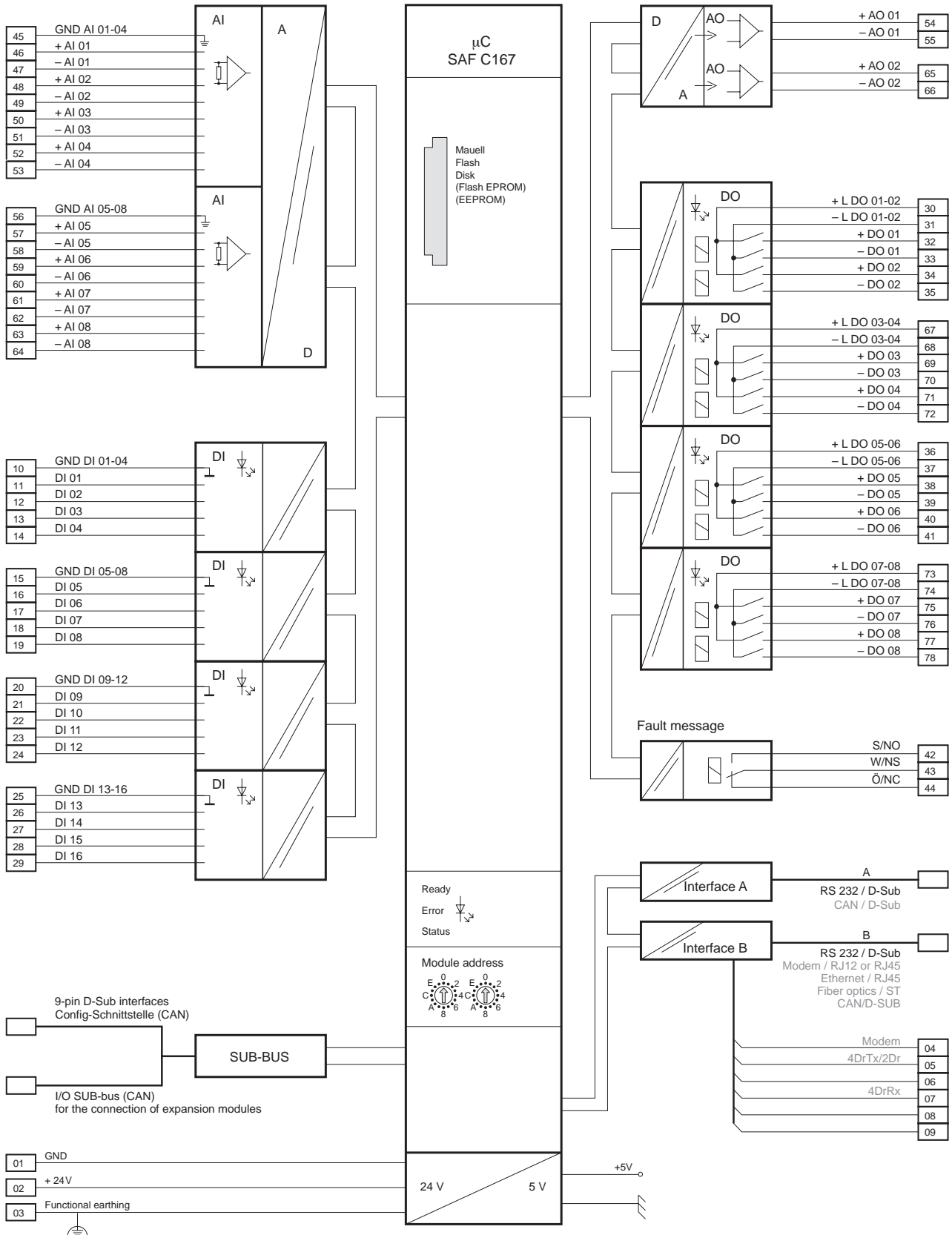

ME30 compact module view (e. g. device version M12 3232)

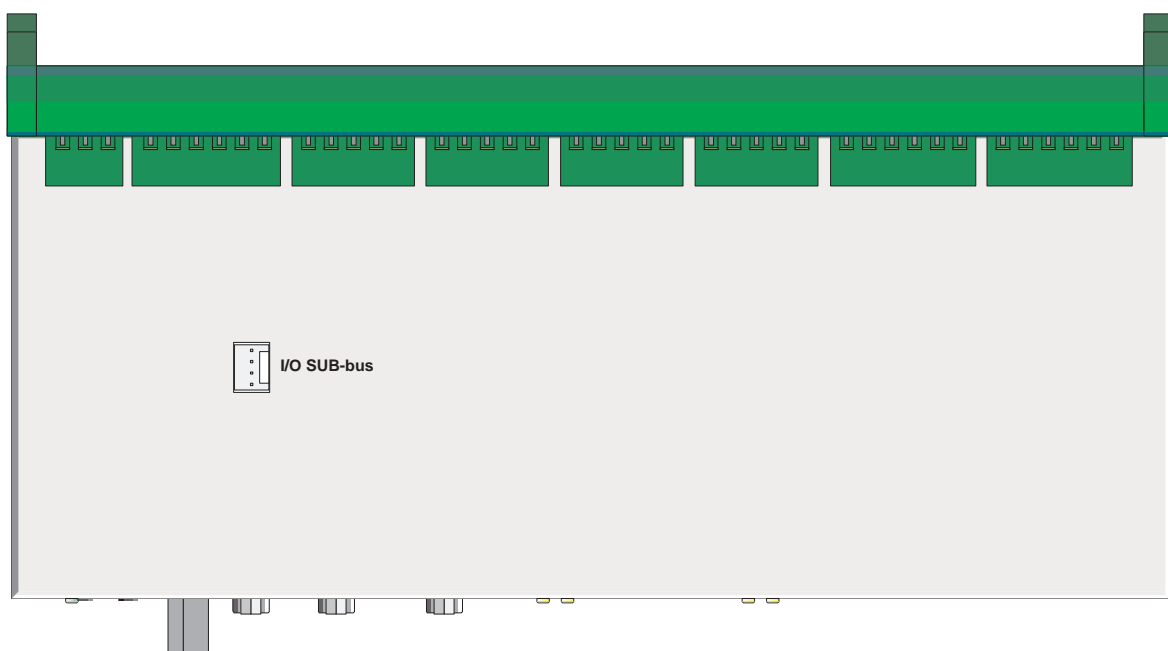
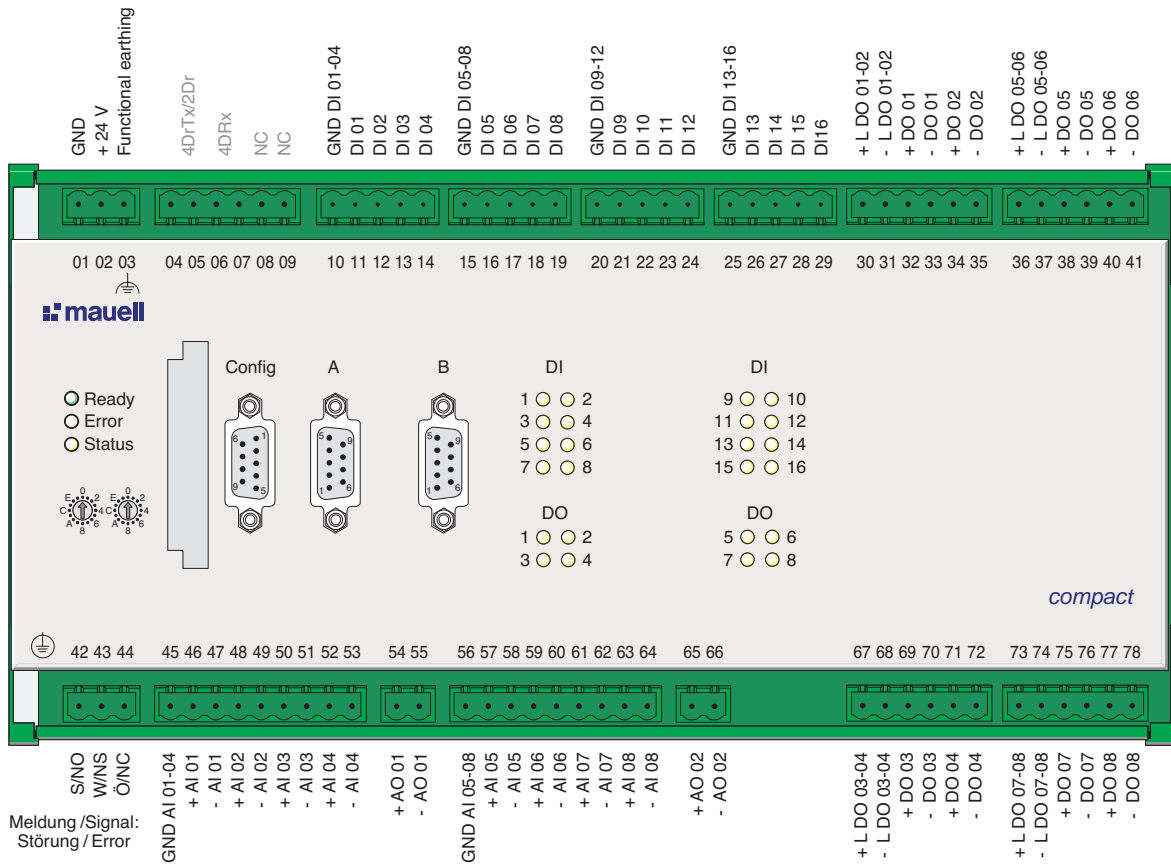

ME30 process IT

ME30 compact modular expansion via CANopen bus

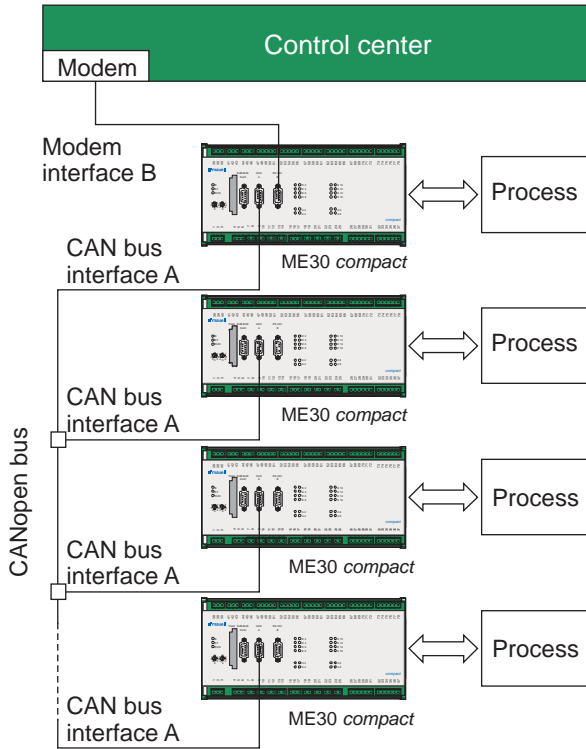

ME30 compact connection using leased line modems

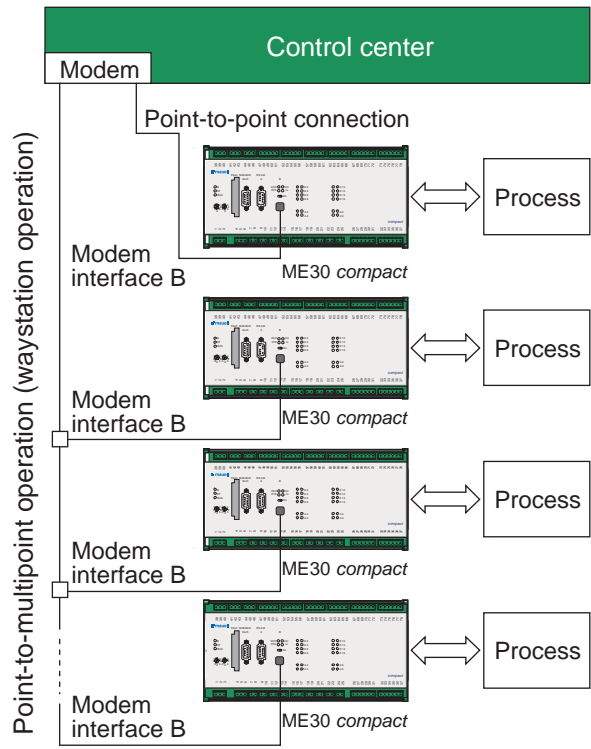

Interconnection of two ME30 compact systems via CANopen/ fiber optics and RS 232 connection to the control center

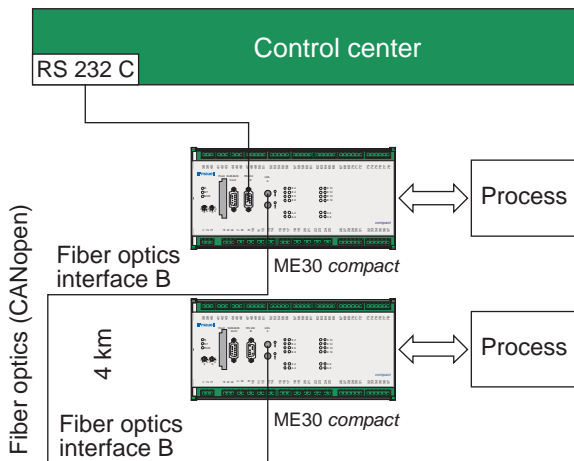

ME30 compact connection using GSM mobile radio telephone networks

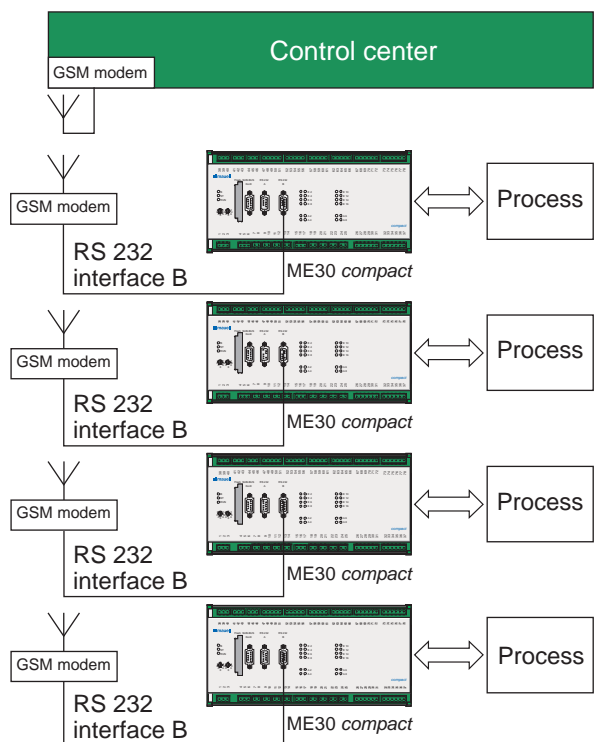

ME30 compact connection via modem interface, with selecting mode

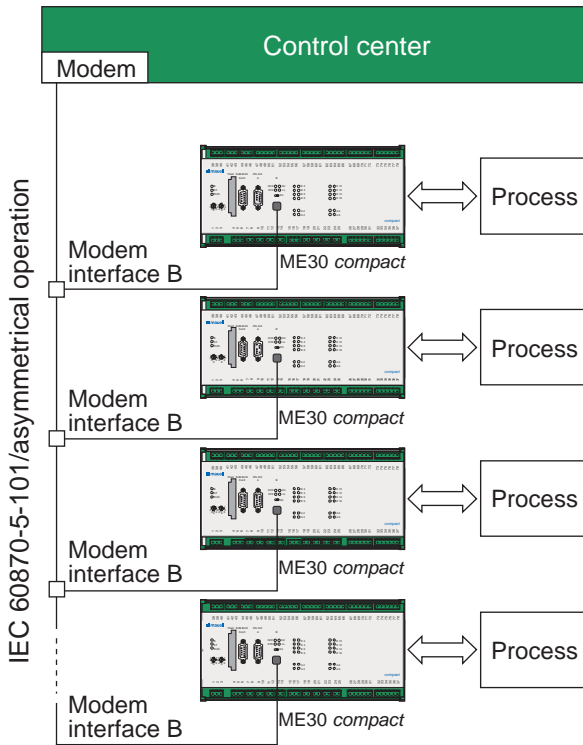

ME30 compact connection to control center via modem, expansion with I/O submodules of the ME 30 telmatic system, LCD display and radio clock; operator control and monitoring with ME30 panel

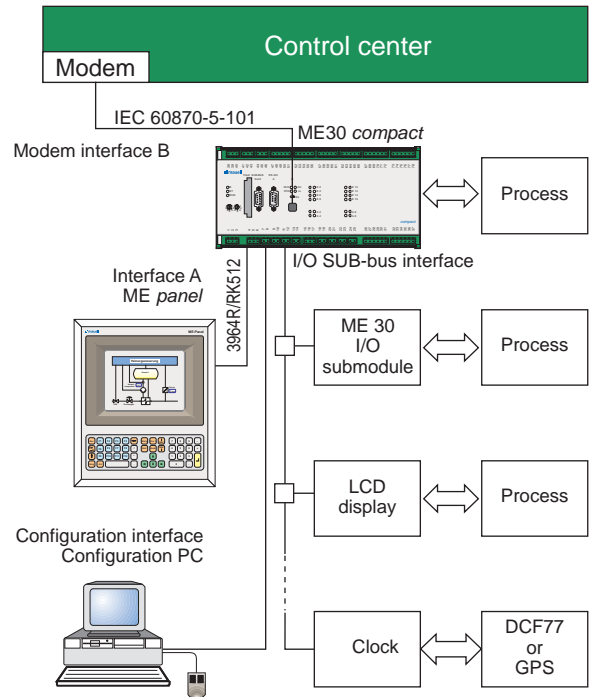

ME30 compact connection via Ethernet using TCP/IP acc. to IEC 60870-5-104

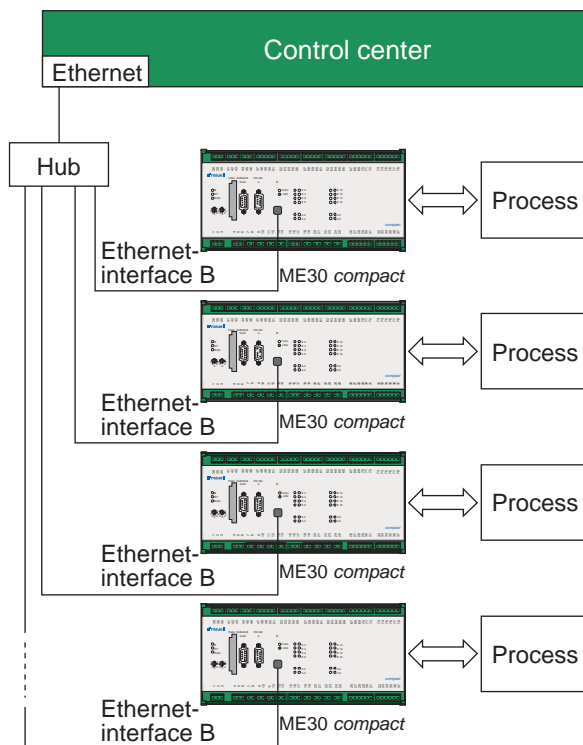

Connection of ME30 process IT devices via CANopen

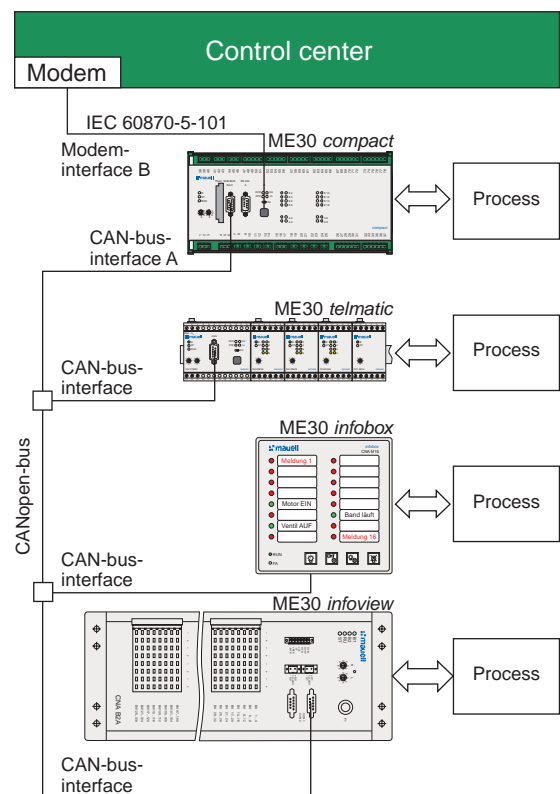

Representatives

Germany

Helmut Mauell GmbH

Am Rosenhügel 1–7

D-42553 Velbert

Tel.: +49 (0)20 53/1 30

Fax.: +49 (0)20 53/1 36 53

Internet: www.mauell.com

E-Mail: info@mauell.com

For an up-to-date list of all our representatives and branch offices, please visit our homepage: www.mauell.com

Representatives and Branch Offices

All Over The World:

Abu Dhabi U.A.E.

Argentina

Austria

Belgium

Brazil

Czech

Republic

Denmark

Finland

France

Great Britain

Hungary

Iran

Korea

Kuwait

Netherlands

Norway

Poland

Singapore

Spain

Sweden

Switzerland

Turkey

USA

mauell
*... your partner
in automation*

