

DC Ground and Voltage Monitoring Devices



GEÜ 02, GSÜ 02 and GESÜ 02

Contents	Page
Application, Construction and Function	4
Technical Data and Dimension Prints	5
Block Diagrams for Flush Mounting Devices	6
Block Diagrams for Surface Mounting Devices	9

Application, Construction and Function

Application

The DC ground and voltage monitoring device GESÜ 02 has been designed for continuously monitoring the insulation resistance as well as the voltage of DC networks. Especially with battery powered control- and monitoring systems the GESÜ 02 will remarkably improve the system reliability.

Construction

The GESÜ 02 uses time proven industrial electronic components. All circuitry is on two PCB's, Euro-one size, 100 mm x 160 mm which are plugged into a sheet steel housing with 144 mm x 144 mm front bezel dimensions. All control-elements such as set-point adjusters, test- and acknowledgement push-buttons are placed on the front panel. All connections are made with screw type terminals at the front with the surface mounting or the rear with the flash mounting type. The terminal blocks are fitted with covers for electrical protection. The ground fault and the voltage monitoring sections operate independently from one another. For remote signalling there are three floating NO-contacts on each PCB. External suppression or acknowledgement of alarms is possible.

Available Modules

As well as a combined ground fault and voltage monitoring device GESÜ 02, both modules can be obtained separately i.e. as ground fault monitoring device GEÜ 02, or as voltage monitoring device GSÜ 02. The housing can be a flush mounting or surface mounting type, and should be specified at time of order. The modules are always fitted in the same housing. All functions and terminal designations are identical irrespective of combination. Please note that the terminal assignment of the flush mounting type is not like the surface mounting type. Additionally both modules are available without housing for rack mounting by the customer.

Function

Ground fault monitoring

The ground fault monitoring circuitry has been designed as a measuring bridge in such a way, that the insulation of the positive conductor as well as that of the negative is monitored. Under normal conditions, i.e. both conductors having the same insulation resistance, the measuring bridge is balanced. With a ground fault, the ground potential shifts towards the conductor with the lower insulation resistance. Size and direction of the shift are calculated and compared with the set point. Upon detection of a fault, after an internally adjustable delay, the corresponding relays are energized. Simultaneous faults in the same direction on both poles cannot be detected. Alarms are given as negative or positive pole ground fault. A group alarm is given too. Simultaneously with the alarm the fault is indicated by an LED on the front panel. The alarm signal remains until it is acknowledged, even though the measured value may return to normal. Using the two test push-buttons, the operation of the measuring bridge can be proved.

By connecting input terminals the alarms are suppressed. Via terminals remote acknowledgement is possible.

Voltage monitoring

The voltage monitoring circuitry has been designed as a measuring bridge to detect overvoltage as well as undervoltage. With normal conditions, i.e. when the voltage conforms with the set point, the bridge is balanced. When the voltage shifts from the set point, the bridge detects the size and direction of the shift. In this fault condition, after an internally adjustable delay, the corresponding relays are energized. Alarm is given as an overvoltage or undervoltage alarm as well as group alarm. The alarm signal stays until it is acknowledged, even though the measured voltage may return to normal. Simultaneously with the alarm signal the fault is indicated by an LED in the front panel. By connecting input terminals the alarms can be suppressed. Via terminals remote acknowledgement is possible.

Technical Data and Dimension Prints

Monitoring

Rated voltages	24 V, 48 V, 60 V, 110 V, 220 V DC
Operating voltage	$U_N \pm 25\%$
Auxiliary voltage	230 V AC
Power consumption	10 VA
Response delay	0,2 s upto 5 s (adjustable)

Input currents

Flush Mounting Terminals	Surface Mounting Terminals	Input Currents
9-10, 25-26	1-2, 4-5	2,5 mA
5-8, 20-23	9-10, 14-15	40 mA
6-7, 21-22	7-8, 12-13	1,2 mA

Voltage monitoring

Upper pick up value $\Delta U \uparrow$	$1,03 U_N$ upto $1,20 U_N$
Lower pick up value $\Delta U \downarrow$	$0,8 U_N$ upto $0,97 U_N$
Hysteresis	$0,02 U_N$
Response value R+ / R-	$\leq 0,85$ upto $\leq 0,15$
Response value R- / R+	$\leq 0,85$ upto $\leq 0,15$
Hysteresis	0,02

Ground Fault Monitoring

Contact load	Surface Mounting Terminals	Contact Load
Flush Mounting Terminals	21-22, 23-24, 25-26, 27-28, 29-30	250 V, 1 A, max. 20 W
1-2, 3-4, 14-15, 16-17, 18-19		

Mechanical Data

Protection	IP 40, DIN 40050
Test voltage to ground	2 kV, 50 Hz
Ambient temperature	- 20 °C upto 40 °C
Mounting	Flush- and surface mounting
Terminals (screw type)	4 mm ² (max.)
Weight:	
Surface mounting type	3,5 kgm
Flush mounting type	3,3 kgm

Dimension Prints

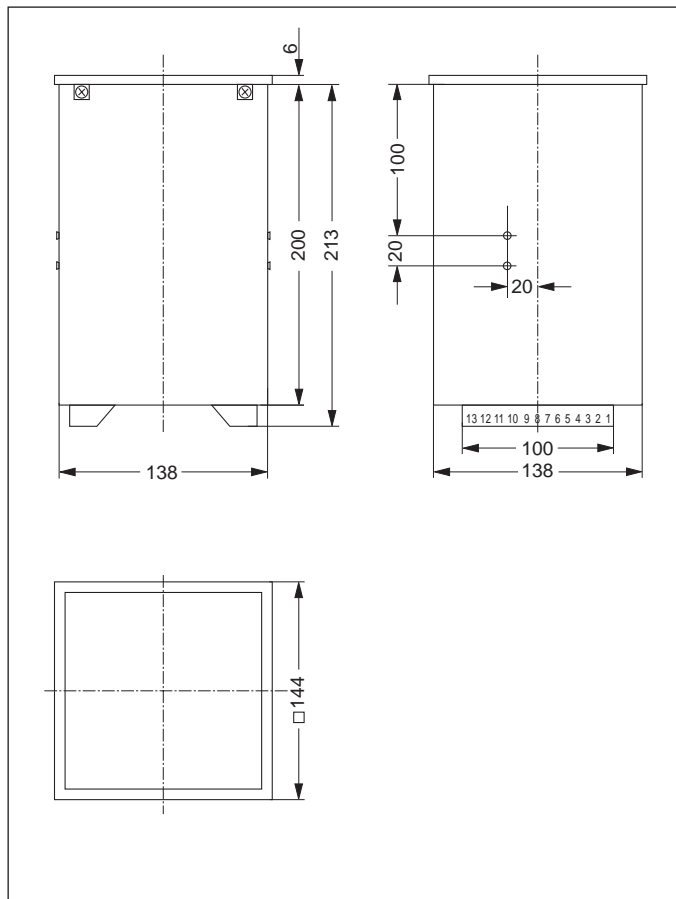

Flush Mounting

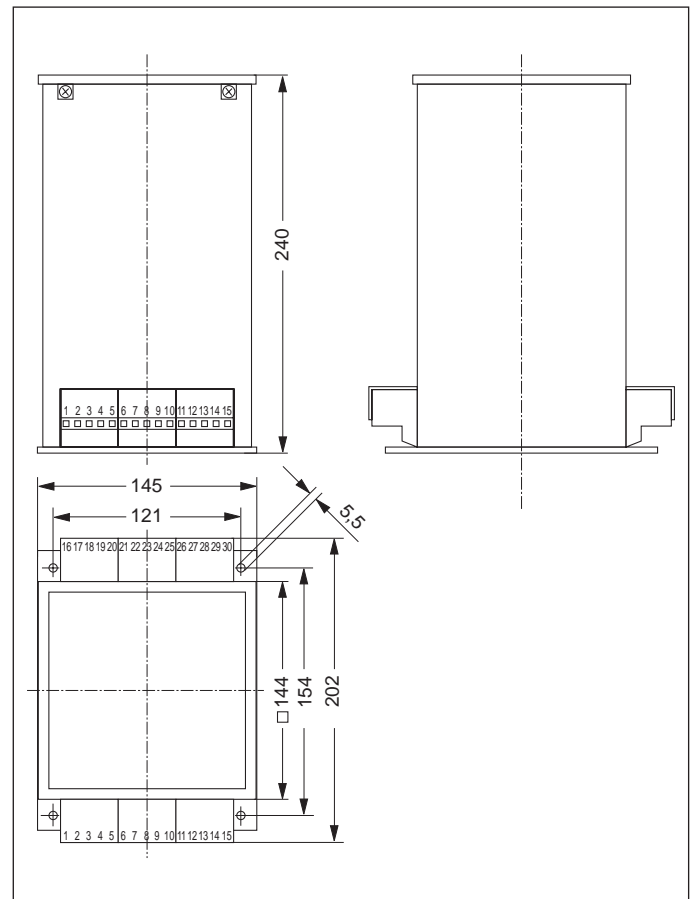

Surface Mounting

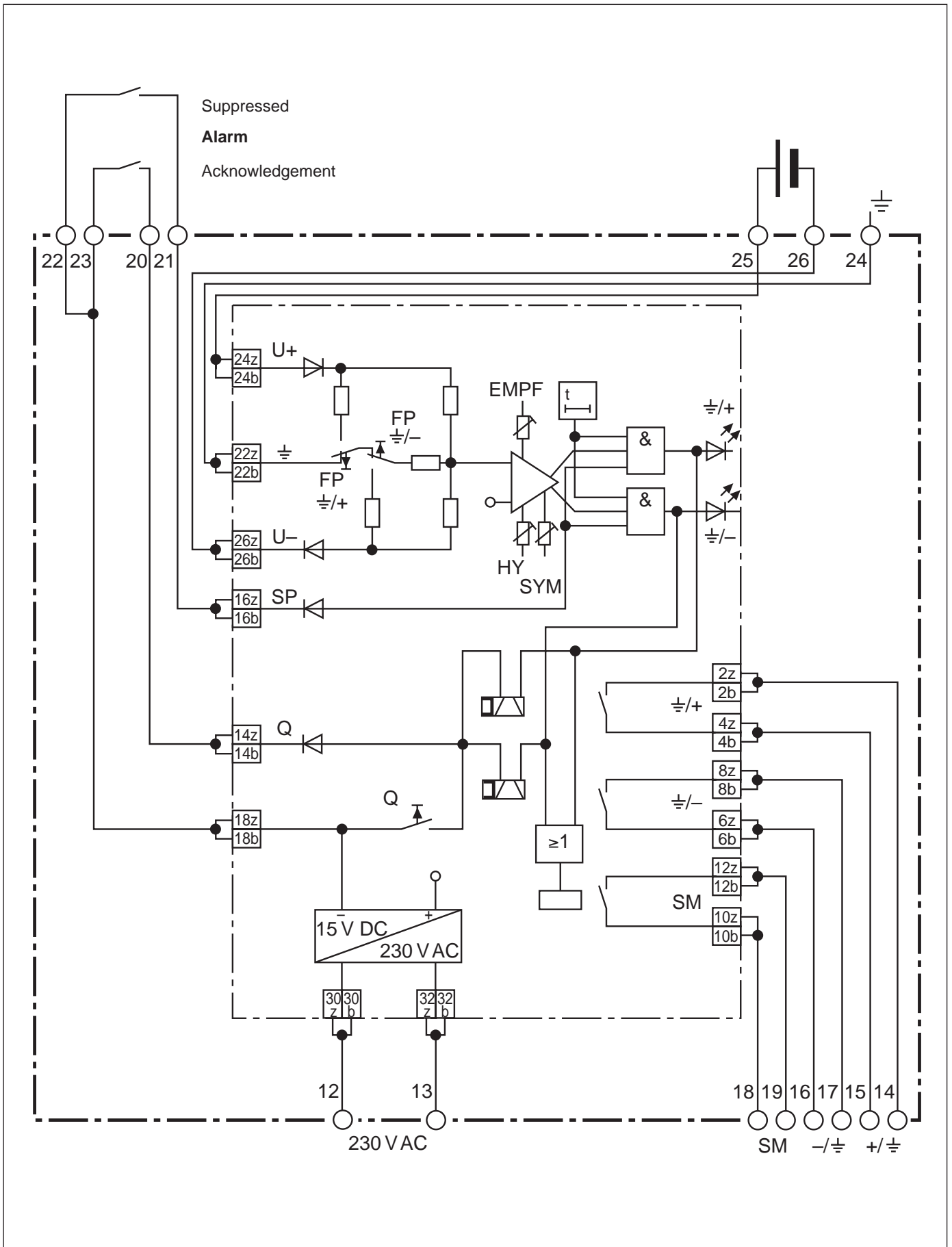

Ground Fault Monitoring Device GEÜ 02 for Flush Mounting

Block Diagrams

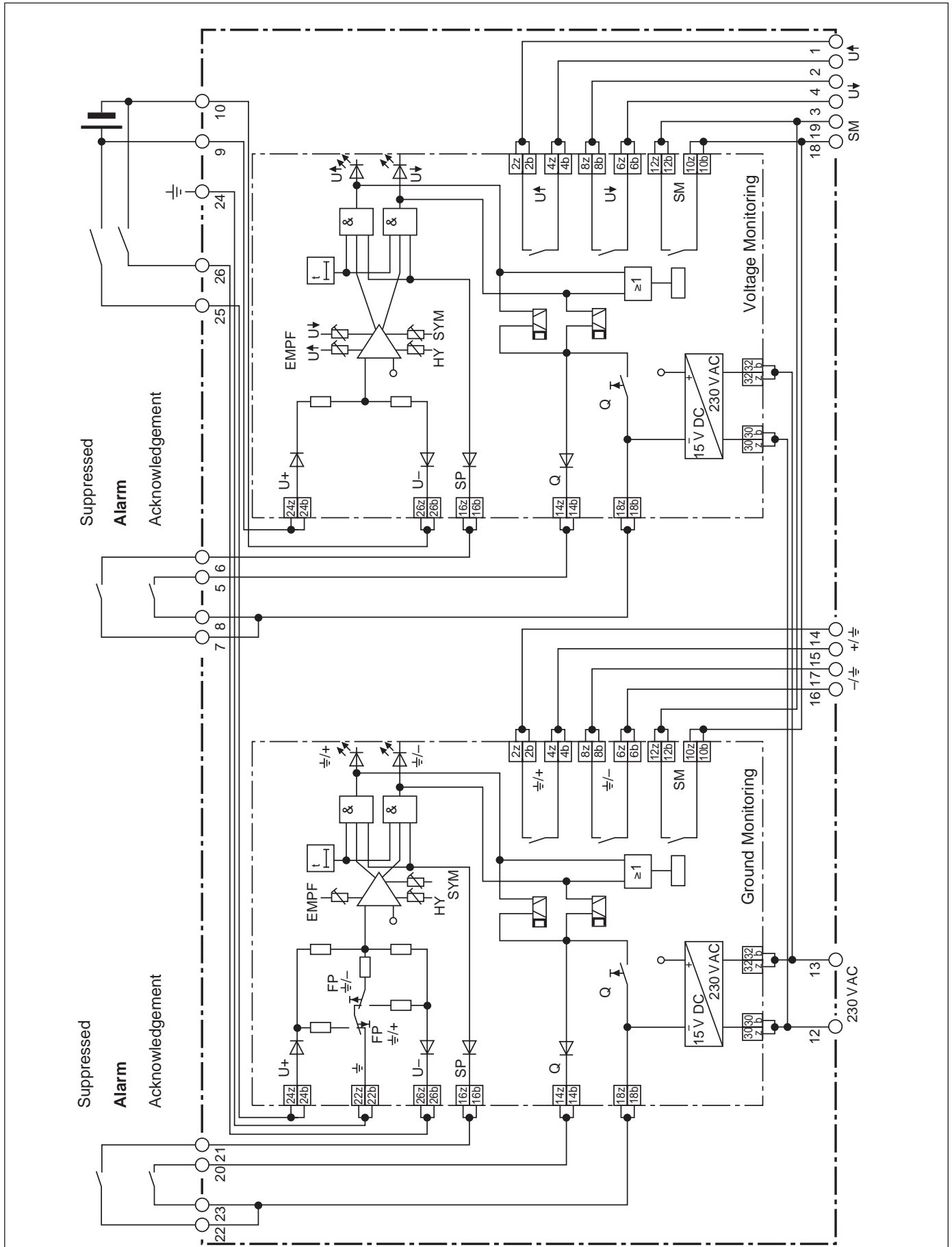

DC Ground and Voltage Monitoring Device GESÜ 02 for Flush Mounting

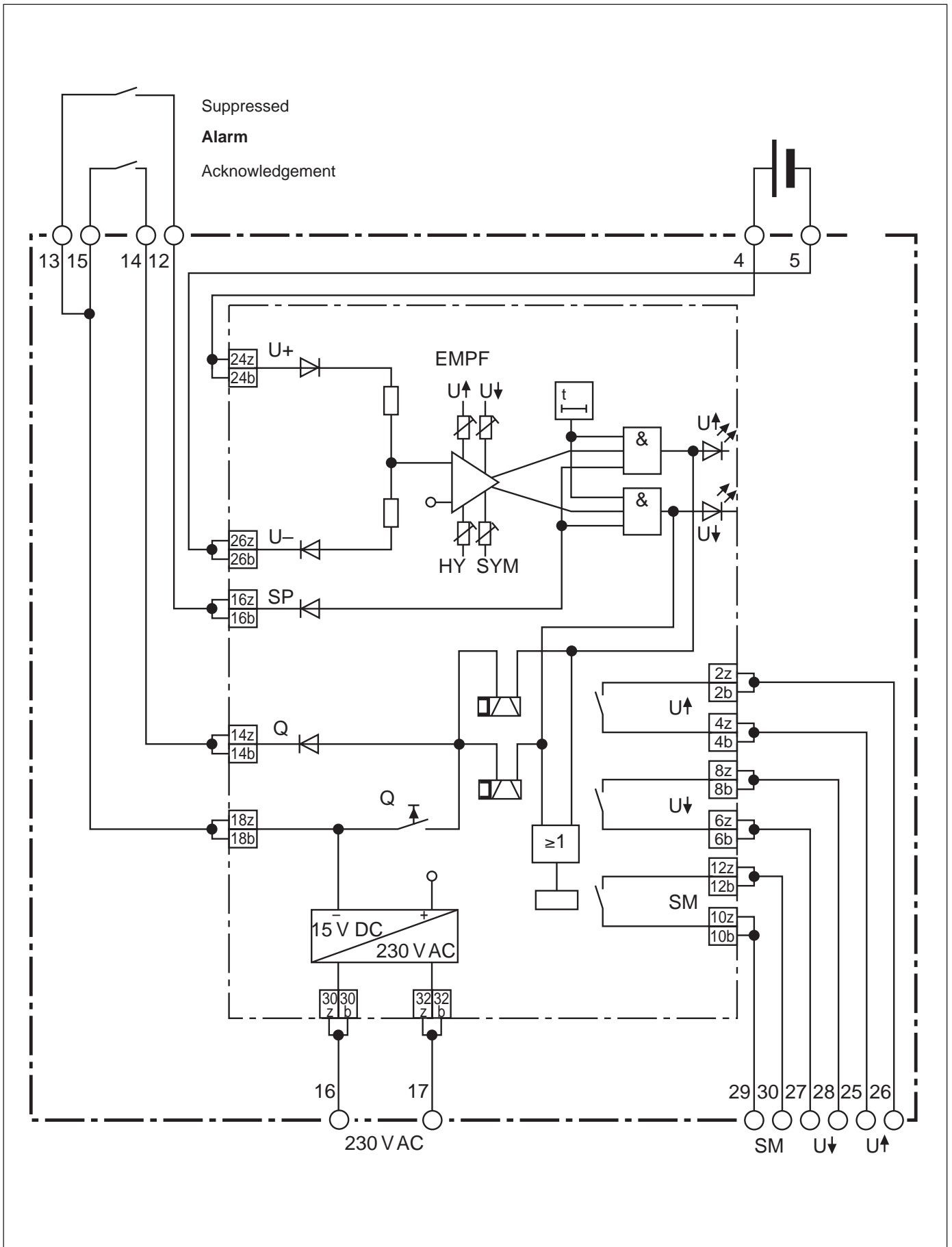

Voltage Monitoring Device GSÜ 02 for Surface Mounting

Block Diagrams

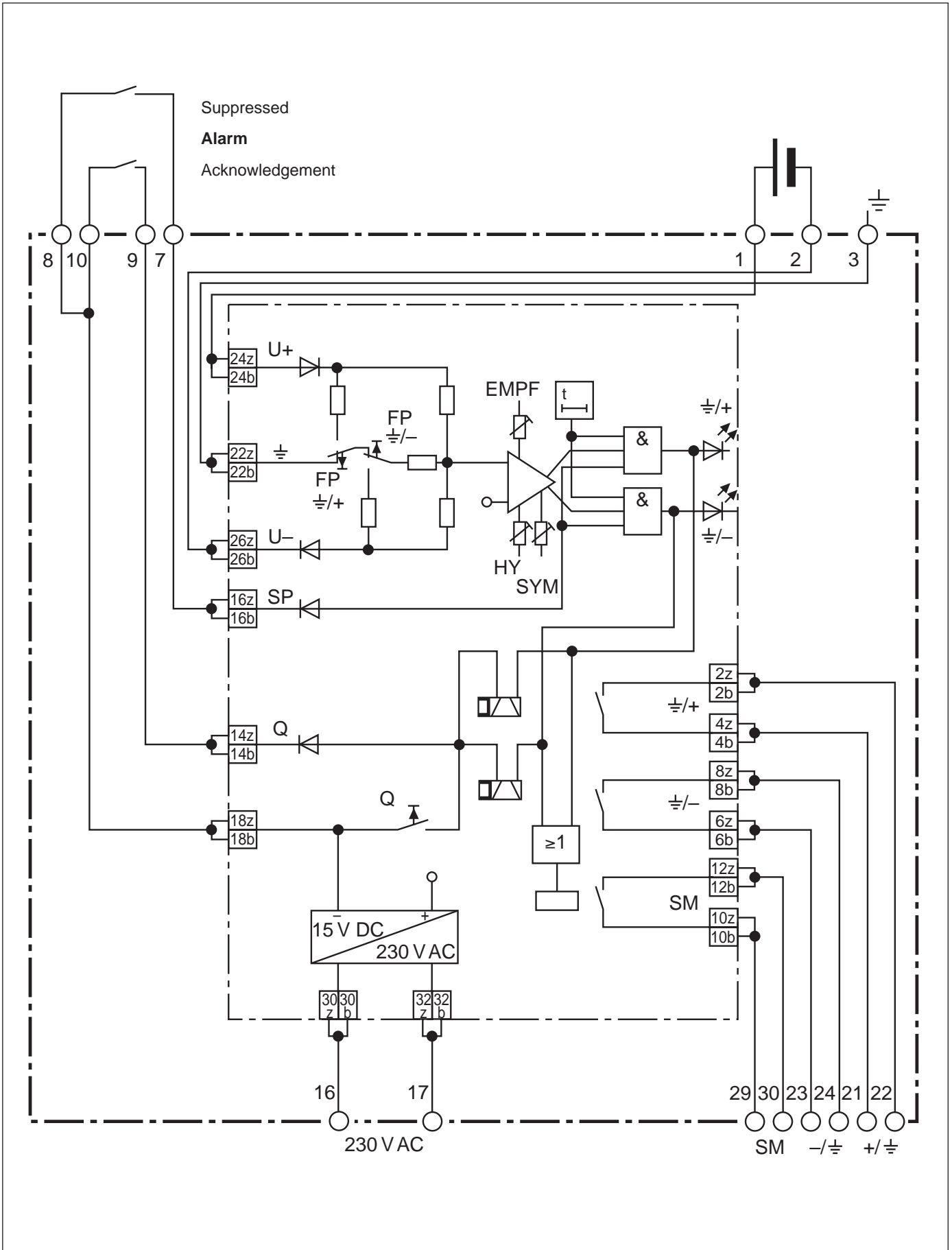

Ground Fault Monitoring Device GEÜ 02 for Surface Mounting

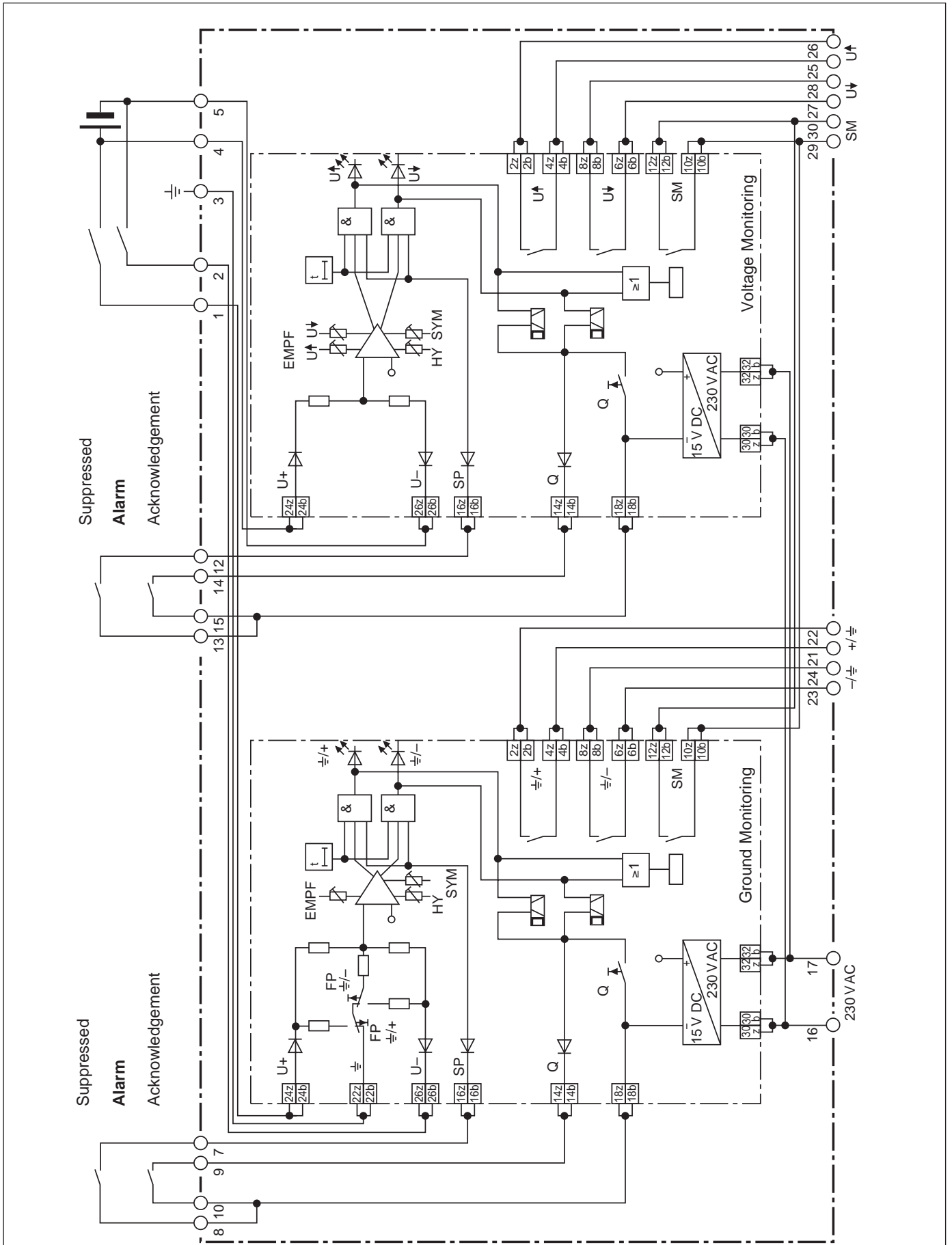

DC Ground and Voltage Monitoring Device GESÜ 02 for Surface Mounting

Representatives

Germany

Helmut Mauell GmbH

Am Rosenhügel 1–7

D-42553 Velbert

Tel.: +49 (0)20 53/1 30

Fax.: +49 (0)20 53/1 36 53

Internet: www.mauell.com

E-Mail: info@mauell.com

For an up-to-date list of all our representatives and branch offices, please visit our homepage: www.mauell.com

Representatives and Branch Offices

All Over The World:

Abu Dhabi U.A.E.

Argentina

Austria

Belgium

Brazil

Czech

Republic

Denmark

Finland

France

Great Britain

Hungary

Iran

Korea

Kuwait

Netherlands

Norway

Poland

Singapore

Spain

Sweden

Switzerland

Turkey

USA

*... your partner
in automation*

